

Approval body for construction products  
and types of construction

Bautechnisches Prüfamt

An institution established by the Federal and  
Laender Governments



## European Technical Assessment

ETA-11/0283  
of 10 January 2020

English translation prepared by DIBt - Original version in German language

### General Part

Technical Assessment Body issuing the  
European Technical Assessment:

Deutsches Institut für Bautechnik

Trade name of the construction product

S+P screws

Product family  
to which the construction product belongs

S+P screws for use in timber construction

Manufacturer

Schäfer + Peters GmbH  
Zeilbaumweg 32  
74613 Öhringen  
DEUTSCHLAND

Manufacturing plant

Werk 3, Werk 4, Werk 5, Werk 8, Werk 9, Werk 10,  
Werk 11, Werk 12, Werk 13, Werk 14, Werk 15, Werk 16

This European Technical Assessment  
contains

50 pages including 4 annexes which form an integral part  
of this assessment

This European Technical Assessment is  
issued in accordance with Regulation (EU)  
No 305/2011, on the basis of

EAD 130118-01-0603

This version replaces

ETA-11/0283 issued on 18 July 2016

The European Technical Assessment is issued by the Technical Assessment Body in its official language. Translations of this European Technical Assessment in other languages shall fully correspond to the original issued document and shall be identified as such.

Communication of this European Technical Assessment, including transmission by electronic means, shall be in full. However, partial reproduction may only be made with the written consent of the issuing Technical Assessment Body. Any partial reproduction shall be identified as such.

This European Technical Assessment may be withdrawn by the issuing Technical Assessment Body, in particular pursuant to information by the Commission in accordance with Article 25(3) of Regulation (EU) No 305/2011.

## Specific Part

### 1 Technical description of the product

SP-HBS, SP-Drill, SP-Super-Drill, T-Drill and TBS-Drill screws are self-tapping screws made from special stainless steel. Screws made from stainless steel no. 1.4006 are hardened. They have an antifriction coating. The outer thread diameter is not less than 3.0 mm and not greater than 10.0 mm. The overall length of the screws is ranging from 12 mm to 400 mm. Further dimensions are shown in Annex 4. The washers are made from stainless steel. The dimensions of the washers are given in Annex 4.

### 2 Specification of the intended use in accordance with the applicable European Assessment Document

The performances given in Section 3 are only valid if the screws are used in compliance with the specifications and conditions given in Annex 1 to 3.

Durability is only ensured if the specifications of intended use according to Annex 1 to 3 are taken into account.

The verifications and assessment methods on which this European Technical Assessment is based lead to the assumption of a working life of the screws of at least 50 years. The indications given on the working life cannot be interpreted as a guarantee given by the producer, but are to be regarded only as a means for choosing the right products in relation to the expected economically reasonable working life of the works.

### 3 Performance of the product and references to the methods used for its assessment

#### 3.1 Mechanical resistance and stability (BWR 1)

Essential characteristic	Performance
Dimensions	See Annex 4
Characteristic yield moment	See Annex 2
Bending angle	See Annex 2
Characteristic withdrawal parameter	See Annex 2
Characteristic head pull-through parameter	See Annex 2
Characteristic tensile strength	See Annex 2
Characteristic yield strength	No performance determined
Characteristic torsional strength	See Annex 2
Insertion moment	See Annex 2
Spacing, end and edge distances of the screws and minimum thickness of the wood based material	See Annex 2
Slip modulus for mainly axially loaded screws	See Annex 2
Durability against corrosion	See Annex 2

**3.2 Safety in case of fire (BWR 2)**

Essential characteristic	Performance
Reaction to fire	Class A1

**3.3 Safety and accessibility in use (BWR 4)**

Same as BWR 1

**4 Assessment and verification of constancy of performance (AVCP) system applied, with reference to its legal base**

In accordance with EAD No. 130118-01-0603 the applicable European legal act is: 97/176/EC.  
The system to be applied is: 3

**5 Technical details necessary for the implementation of the AVCP system, as provided for in the applicable EAD**

Technical details necessary for the implementation of the AVCP system are laid down in the control plan deposited with Deutsches Institut für Bautechnik.

Issued in Berlin on 10 January 2020 by Deutsches Institut für Bautechnik

BD Dipl.-Ing. Andreas Kummerow  
Head of Department

*beglaubigt:*  
Dewitt

## Annex 1 Specifications of intended use

### A.1.1 Use of the S+P screws only for:

- Static and quasi-static loads

### A.1.2 Base materials

The screws are used for connections in load bearing timber structures between timber members or between those members and steel members:

- Solid timber (softwood) according to EN 14081-1<sup>1</sup>,
- Glued laminated timber (softwood) according to EN 14080<sup>2</sup>,
- Laminated veneer lumber LVL (softwood) according to EN 14374<sup>3</sup>, arrangement of the screws only perpendicular to the plane of the veneers,
- Glued solid timber (softwood) according to EN 14080 or national provisions that apply at the installation site,
- Cross-laminated timber (softwood) according to European Technical Approvals/Assessments or national provisions that apply at the installation site.

The screws can be used for connecting the following wood-based panels to the timber members mentioned above:

- Plywood according to EN 636<sup>4</sup> and EN 13986<sup>5</sup>,
- Oriented Strand Board, OSB according to EN 300<sup>6</sup> and EN 13986,
- Particleboard according to EN 312<sup>7</sup> and EN 13986,
- Fibreboards according to EN 622-2<sup>8</sup>, EN 622-3<sup>9</sup> and EN 13986,
- Cement-bonded particle boards according to EN 634-2<sup>10</sup> and EN 13986,
- Solid-wood panels according to EN 13353<sup>11</sup> and EN 13986.

Wood-based panels are only arranged on the side of the screw head.

SP-HBS and SP-Drill screws with an outer thread diameter of at least 6 mm are also used for the fixing of thermal insulation material on top of rafters.

1	EN 14081-1:2005+A1:2011	Timber structures – Strength graded structural timber with rectangular cross section – Part 1: General requirements
2	EN 14080:2013	Timber structures - Glued laminated timber and glued solid timber - Requirements
3	EN 14374:2004	Timber structures - Structural laminated veneer lumber - Requirements
4	EN 636:2012+A1:2015	Plywood - Specifications
5	EN 13986:2004+A1:2015	Wood-based panels for use in construction - Characteristics, evaluation of conformity and marking
6	EN 300:2006	Oriented strand boards (OSB) – Definition, classification and specifications
7	EN 312:2010	Particleboards - Specifications
8	EN 622-2:2004	Fibreboards – Specifications – Part 2: Requirements for hardboards
9	EN 622-3:2004	Fibreboards - Specifications - Part 3: Requirements for medium boards
10	EN 634-2:2007	Cement-bonded particleboards – Specifications – Part 2: Requirements for OPC bonded particleboards for use in dry, humid and external conditions
11	EN 13353:2008+A1:2011	Solid wood panels (SWP) – Requirements

S+P screws	Annex 1.1
Specifications of intended use	

### A.1.3 Use Conditions (environmental conditions)

The corrosion protection of the S+P screws is specified in Annex A.2.6.

### A.1.4 Installation provisions

EN 1995-1-1<sup>12</sup> in conjunction with the respective national annex applies for the installation.

The screws are either driven into the timber member made of softwood without pre-drilling or in pre-drilled holes with a diameter not exceeding the inner thread diameter.

The screw holes in steel members are pre-drilled with an adequate diameter greater than the outer thread diameter.

A minimum of two screws is used for connections in load bearing timber structures.

If screws with an outer thread diameter  $d \geq 8$  mm are used in load-bearing timber structures, the structural solid or glued laminated timber, laminated veneer lumber and similar glued members is from spruce, pine or fir.

In the case of fastening battens on thermal insulation material on top of rafters the screws are driven in the rafter through the battens and the thermal insulation material without pre-drilling in one sequence.

Countersunk head screws can be used with washers according to Annex 4. After inserting the screw the washers touch the surface of the timber member completely. Screws made from stainless steel are used with washers made from stainless steel.

By fastening screws in timber members the head of the screws is flush with the surface of the timber member. For screws with a pan washer or hexagon head the head part remains unconsidered.

<sup>12</sup> EN 1995-1-1:2004+A1:2008+A2:2014

Eurocode 5: Design of timber structures – Part 1-1: General - Common rules and rules for buildings

S+P screws	Annex 1.2
Installation provisions	

## ANNEX 2 – Characteristic values of the load-carrying capacities

Table A.2.1 Characteristic load-carrying capacities of S+P self-tapping screws

Outer thread diameter [mm]		3.0	3.2	3.5	4.0	4.5	5.0	5.5	6.0	8.0	10.0
Characteristic yield moment $M_{y,k}$ [Nm]	SP-HBS and SP-Drill	0.9	1.2	1.5	1.7	3.0	3.9	-	6.3	13.0	24.0
	SP-HBS and SP-Drill hardened	1.5	2.0	2.8	3.3	3.8	5.0	-	9.0	13.0	24.0
	SP-Super-Drill	-	-	-	3.9	5.2	6.9	-	11.1	-	-
	TBS-Drill	-	-	-	-	-	-	6.0	-	-	-
	T-Drill and TBS-Drill hardened	-	-	-	-	-	10.0	12.0	-	-	-
Characteristic tensile strength $f_{tens,k}$ [kN]	SP-HBS and SP-Drill	1.7	2.0	2.4	3.1	4.0	4.4	-	7.1	13.0	20.0
	SP-HBS and SP-Drill hardened	2.8	3.2	3.8	5.0	6.4	7.9	-	11.0	13.0	20.0
	SP-Super-Drill	-	-	-	5.0	5.9	7.9	-	11.0	-	-
	TBS-Drill	-	-	-	-	-	-	7.1	-	-	-
	T-Drill and TBS-Drill hardened	-	-	-	-	-	7.9	9.5	-	-	-
Characteristic torsional strength $f_{tor,k}$ [Nm]	SP-HBS and SP-Drill	0.8	1.3	1.4	2.2	2.7	3.8	-	6.0	15.0	30.0
	SP-HBS and SP-Drill hardened	1.4	1.9	2.7	3.5	4.3	5.9	-	11.5	15.0	30.0
	SP-Super-Drill	-	-	-	3.5	5.0	8.0	-	14.0	-	-
	TBS-Drill	-	-	-	-	-	-	8.0	-	-	-
	T-Drill and TBS-Drill hardened	-	-	-	-	-	9.5	11.5	-	-	-

### A.2.1 General

All S+P screws achieve a bending angle  $\alpha$  of at least  $45/d^{0.7} + 20$ , where  $d$  is the outer thread diameter of the screws.

The minimum penetration length of the threaded part of the screw  $l_{ef}$  shall be

$$l_{ef} = \frac{4 \cdot d}{\sin \alpha}$$

where

$\alpha$  angle between screw axis and grain direction

$d$  outer thread diameter of the screw.

The outer thread diameter of screws inserted in cross-laminated timber is at least 6 mm.

To connect cross-laminated timber the inner thread diameter  $d_1$  of the screws is greater than the maximal width of the gaps in the layer.

S+P screws	Annex 2.1
Characteristic values of the load-carrying capacities	

### A.2.2 Laterally loaded screws

The outer thread diameter  $d$  is used as effective diameter of the screw according to EN 1995-1-1.

### A.2.3 Axially loaded screws

The axial slip modulus  $K_{ser}$  of the threaded part of a screw for the serviceability limit state per side shall be taken independent of angle  $\alpha$  to the grain as:

$$K_{ser} = 780 \cdot d^{0,2} \cdot l_{ef}^{0,4} \quad [N/mm] \quad (2.1)$$

where

$d$  outer thread diameter of the screw [mm]

$l_{ef}$  penetration length of the of the threaded part of the screw in the timber member [mm].

#### A.2.3.1 Axial withdrawal capacity

The characteristic withdrawal parameter at an angle of  $\alpha = 90^\circ$  to the grain based on a characteristic density of the wood-based member of  $350 \text{ kg/m}^3$  is

$f_{ax,90,k} = 13.7 \text{ N/mm}^2$  for SP-HBS and SP-Super-Drill screws

$f_{ax,90,k} = 10.0 \text{ N/mm}^2$  for SP-Drill, SP-HBS hardened, T-Drill and TBS-Drill screws.

For LVL a maximum characteristic density of  $500 \text{ kg/m}^3$  shall be used in equation (8.40a) of EN 1995-1-1.

For screws penetrating more than one layer of cross-laminated timber the different layers may be taken into account proportionally. In the lateral surfaces of the cross-laminated timber the screws shall be fully inserted in one layer.

#### A.2.3.2 Head pull-through capacity

The characteristic value of the head pull-through parameter for SP-screws for a characteristic density of  $350 \text{ kg/m}^3$  of the timber and for wood-based panels like

- Plywood according to EN 636 and EN 13986
- Oriented Strand Board, OSB according to EN 300 and EN 13986
- Particleboard according to EN 312 and EN 13986
- Fibreboards according to EN 622-2, EN 622-3 and EN 13986
- Cement-bonded particle board according to EN 634-2 and EN 13986
- Solid wood panel according to EN 13353 and EN 13986

with a thickness of more than 20 mm is

$$f_{head,k} = 9.4 \text{ N/mm}^2.$$

For wood-based panels a maximum characteristic density of  $380 \text{ kg/m}^3$  shall be used in equation (8.40b) of EN 1995-1-1.

For wood based panels with a thickness  $12 \text{ mm} \leq t \leq 20 \text{ mm}$  the characteristic value of the head pull-through parameter for S+P screws is:

$$f_{head,k} = 8 \text{ N/mm}^2$$

For wood based panels with a thickness of less than 12 mm the characteristic head pull-through capacity for SP-screws shall be based on a characteristic value of the head pull-through parameter of  $8 \text{ N/mm}^2$ , and limited to 400 N complying with the minimum thickness of the wood based panels of  $1,2 \cdot d$ , with  $d$  as outer thread diameter and the values in Table A.2.2.

S+P screws	Annex 2.2
Characteristic values of the load-carrying capacities	

Table A.2.2 Minimum thickness of wood based panels

Wood based panel	Minimum thickness [mm]
Plywood	6
Fibreboards (hardboards and medium boards)	6
Oriented Strand Boards, OSB	8
Particleboards	8
Cement-bonded particle board	8
Solid wood Panels	12

In steel-to-timber connections the head pull-through capacity is not decisive.

## A.2.4 Spacing, end and edge distances of the screws and minimum thickness of the wood based material

### A.2.4.1 Laterally and/or axially loaded screws

#### Screws in pre-drilled holes

For SP-screws in pre-drilled holes the minimum spacings, end and edge distances are given in EN 1995-1-1, clause 8.3.1.2 and Table 8.2 as for nails in pre-drilled holes. Here, the outer thread diameter  $d$  shall be considered.

Minimum thickness for structural timber members made from solid timber, glued laminated timber, glued solid timber, laminated veneer lumber and cross laminated timber is  $t = 30$  mm for screws with  $d \leq 8$  mm and  $t = 40$  mm for screws with  $d = 10$  mm.

#### Screws in non pre-drilled holes

For SP-screws minimum spacing and distances are given in EN 1995-1-1, clause 8.3.1.2 and Table 8.2 as for nails in non-predrilled holes. Here, the outer thread diameter  $d$  shall be considered.

For Douglas fir members minimum spacing and distances parallel to the grain are increased by 50%.

Minimum distances from loaded or unloaded ends are at least  $15 \cdot d$  for screws with outer thread diameter  $d \geq 8$  mm and timber thickness  $t < 5 \cdot d$ .

Minimum distances from the unloaded edge perpendicular to the grain may be reduced to  $3 \cdot d$  also for timber thickness  $t < 5 \cdot d$ , if the spacing parallel to the grain and the end distance is at least  $25 \cdot d$ .

### A.2.4.2 Only axially loaded screws

For SP-screws the minimum spacings, end and edge distances are given in EN 1995-1-1, clause 8.3.1.2 and Table 8.2 as for nails in non-predrilled holes and clause 8.7.2, Table 8.6.

### A.2.5 Insertion moment

The ratio between the characteristic torsional strength  $f_{tor,k}$  and the mean value of insertion moment  $R_{tor,mean}$  fulfills the requirement for all screws.

### A.2.6 Durability against corrosion

Steel no. 1.4006, 1.4301, 1.4567, 1.4401, 1.4571, 1.4539 and 1.4529 is used for screws made from stainless steel.

Washers are made from steel no. 1.4301.

Contact corrosion shall be avoided.

S+P screws	Annex 2.3
Spacing, end and edge distances and durability against corrosion	

## Annex 3 – Fastening of thermal insulation material on top of rafters (informative)

### A.3.1 General

SP-HBS and SP-Drill screws with an outer thread diameter of at least 6 mm are also used for the fixing of thermal insulation material on top of rafters.

The thickness of the thermal insulation material is up to 300 mm. A thermal insulation material is used that is applicable as insulation on top of rafters.

The battens are from solid timber (softwood) according to EN 14081-1. The minimum thickness  $t$  and the minimum width  $b$  of the battens are given as follows:

Table A.3.1 Minimum thickness and minimum width of the battens

Outer thread diameter [mm]	Minimum thickness $t$ [mm]	Minimum width $b$ [mm]
6 and 8	30	50
10	40	60

Instead of battens the following wood-based panels may be used to cover the thermal insulation material if they are suitable for that use:

- Plywood according to EN 636 and EN 13986,
- Oriented Strand Board, OSB according to EN 300 and EN 13986,
- Particleboard according to EN 312 and EN 13986
- Fibreboards according to EN 622-2, EN 622-3 and EN 13986.

The minimum thickness of the wood-based panels is 22 mm.

The word batten includes the meaning of wood-based panels in the following.

The spacing between screws  $e$  is not more than 1.75 m.

Friction forces are not considered for the design of the characteristic axial load of the screws.

The anchorage of wind suction forces as well as the bending stresses of the battens, respectively, are considered for design. Screws perpendicular to the grain of the rafter (angle  $\alpha = 90^\circ$ ) may be arranged if necessary.

### A.3.2 Parallel inclined screws and thermal insulation material in compression

#### A.3.2.1 Mechanical model

The system of rafter, thermal insulation material on top of rafter and battens parallel to the rafter is considered as a beam on elastic foundation. The batten represents the beam, and the thermal insulation material on top of the rafter the elastic foundation. The minimum compression stress of the thermal insulation material at 10 % deformation, measured according to EN 826<sup>13</sup>, shall be  $\sigma_{(10\%)} = 0,05 \text{ N/mm}^2$ . The batten is loaded perpendicular to the axis by point loads  $F_b$ . Further point loads  $F_s$  are from the shear load of the roof due to dead and snow load, which are transferred from the screw heads into the battens.

<sup>13</sup> EN 826:2013 Thermal insulating products for building applications - Determination of compression behaviour

S+P screws	Annex 3.1
Fastening of the thermal insulation material on top of rafters	

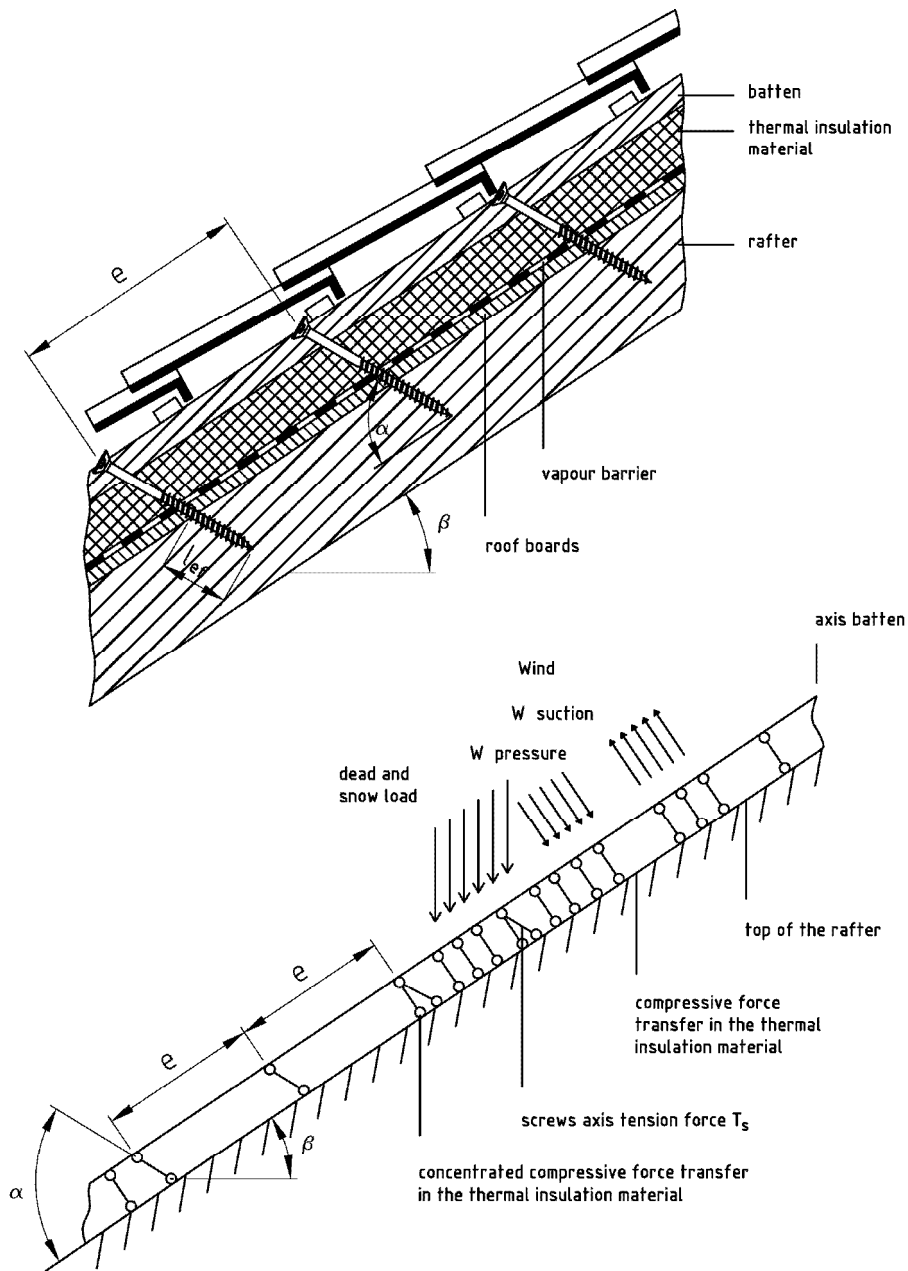

Figure A.3.1 Fastening of the thermal insulation material on top of rafters - structural system for parallel inclined screws

Electronic copy of the ETA by DIBt: ETA-11/0283

S+P screws	Annex 3.2
Fastening of the thermal insulation material on top of rafters	

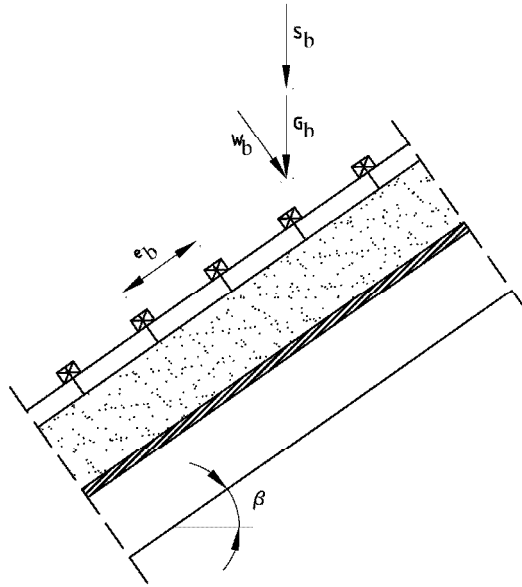

Figure A.3.2 Point loads  $F_b$  perpendicular to the battens

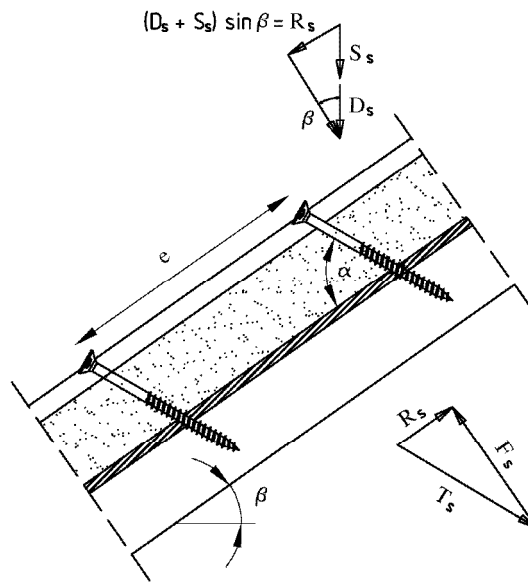

Figure A.3.3 Point loads  $F_s$  perpendicular to the battens, load application in the area of the screw heads

Electronic copy of the ETA by DIBt: ETA-11/0283

S+P screws	Annex 3.3
Fastening of the thermal insulation material on top of rafters	

### A.3.2.2 Design of the battens

It's assumed that the spacing between the counter battens exceeds the characteristic length  $l_{char}$ .

The characteristic values of the bending stresses are calculated as:

$$M_k = \frac{(F_{b,k} + F_{s,k}) \cdot l_{char}}{4} \quad (3.1)$$

where

$$l_{char} = \text{characteristic length } l_{char} = \sqrt[4]{\frac{4 \cdot EI}{w_{ef} \cdot K}} \quad (3.2)$$

$EI$  = bending stiffness of the batten

$K$  = coefficient of subgrade

$w_{ef}$  = effective width of the thermal insulation material

$F_{b,k}$  = characteristic value of the point loads perpendicular to the battens

$F_{s,k}$  = characteristic value of the point loads perpendicular to the battens, load application in the area of the screw heads

The coefficient of subgrade  $K$  may be calculated from the modulus of elasticity  $E_{HI}$  and the thickness  $t_{HI}$  of the thermal insulation material if the effective width  $w_{ef}$  of the thermal insulation material under compression is known. Due to the load extension in the thermal insulation material the effective width  $w_{ef}$  is greater than the width of the batten or rafter, respectively. For further calculations, the effective width  $w_{ef}$  of the thermal insulation material may be determined according to:

$$w_{ef} = w + t_{HI} / 2 \quad (3.3)$$

where

$w$  = minimum from width of the batten or rafter, respectively

$t_{HI}$  = thickness of the thermal insulation material

$$K = \frac{E_{HI}}{t_{HI}} \quad (3.4)$$

The following condition shall be satisfied:

$$\frac{\sigma_{m,d}}{f_{m,d}} = \frac{M_d}{W \cdot f_{m,d}} \leq 1 \quad (3.5)$$

For the calculation of the section modulus  $W$  the net cross section shall be considered.

The characteristic value of the shear stresses shall be calculated according to:

$$V_k = \frac{(F_{b,k} + F_{s,k})}{2} \quad (3.6)$$

The following condition need to be satisfied:

$$\frac{\tau_d}{f_{v,d}} = \frac{1.5 \cdot V_d}{A \cdot f_{v,d}} \leq 1 \quad (3.7)$$

For the calculation of the cross section area the net cross section shall be considered.

S+P screws	Annex 3.4
Fastening of the thermal insulation material on top of rafters	

### A.3.2.3 Design of the thermal insulation material

The characteristic value of the compressive stresses in the thermal insulation material shall be calculated according to:

$$\sigma_k = \frac{1,5 \cdot F_{b,k} + F_{s,k}}{2 \cdot l_{char} \cdot w} \quad (3.8)$$

The design value of the compressive stress shall not be greater than 110 % of the compressive stress at 10 % deformation calculated according to EN 826.

### A.3.2.4 Design of the screws

The screws are loaded predominantly axial. The characteristic value of the axial tension force in the screw may be calculated from the shear loads of the roof  $R_s$ :

$$T_{S,k} = \frac{R_{S,k}}{\cos \alpha} \quad (3.9)$$

The load-carrying capacity of axially loaded screws is the minimum design value of the axial withdrawal capacity of the threaded part of the screw, the head pull-through capacity of the screw and the tensile capacity of the screw according to Annex 2.

In order to limit the deformation of the screw head for thermal insulation material with thickness over 200 mm or with compressive strength below 0.12 N/mm<sup>2</sup>, respectively, the axial withdrawal capacity of the screws are reduced by the factors  $k_1$  and  $k_2$ :

$$F_{ax,\alpha,Rd} = \min \left\{ \frac{f_{ax,d} \cdot d \cdot l_{ef} \cdot k_1 \cdot k_2 \cdot \left( \frac{\rho_k}{350} \right)^{0.8}}{1.2 \cdot \cos^2 \alpha + \sin^2 \alpha}; f_{head,d} \cdot d_h^2 \cdot \left( \frac{\rho_k}{350} \right)^{0.8}; \frac{f_{tens,k}}{\gamma_{M2}} \right\} \quad (3.10)$$

where:

$f_{ax,d}$	design value of the axial withdrawal parameter of the threaded part of the screw [N/mm <sup>2</sup> ]
$d$	outer thread diameter of the screw according to Annex 4 [mm]
$l_{ef}$	penetration length of the threaded part of the screw in the batten, $l_{ef} \geq 40$ mm
$\rho_k$	characteristic density of the timber member [kg/m <sup>3</sup> ], for LVL $\rho_k \leq 500$ kg/m <sup>3</sup>
$\alpha$	angle $\alpha$ between screw axis and grain direction, $30^\circ \leq \alpha \leq 90^\circ$
$f_{head,d}$	design value of the head pull-through parameter of the screw [N/mm <sup>2</sup> ]
$d_h$	head diameter of the screw [mm]
$f_{tens,k}$	characteristic tensile capacity of the screw according to Annex 2 [N]
$\gamma_{M2}$	partial factor according to EN 1993-1-1 in conjunction with the particular national annex
$k_1$	$\min \{1; 220/t_{HI}\}$
$k_2$	$\min \{1; \sigma_{10\%}/0.12\}$
$t_{HI}$	thickness of the thermal insulation material [mm]
$\sigma_{10\%}$	compressive stress of the thermal insulation material under 10 % deformation [N/mm <sup>2</sup> ]

If equation (3.10) is fulfilled, the deflection of the battens does not need to be considered when designing the load-carrying capacity of the screws.

S+P screws	Annex 3.5
Fastening of the thermal insulation material on top of rafters	

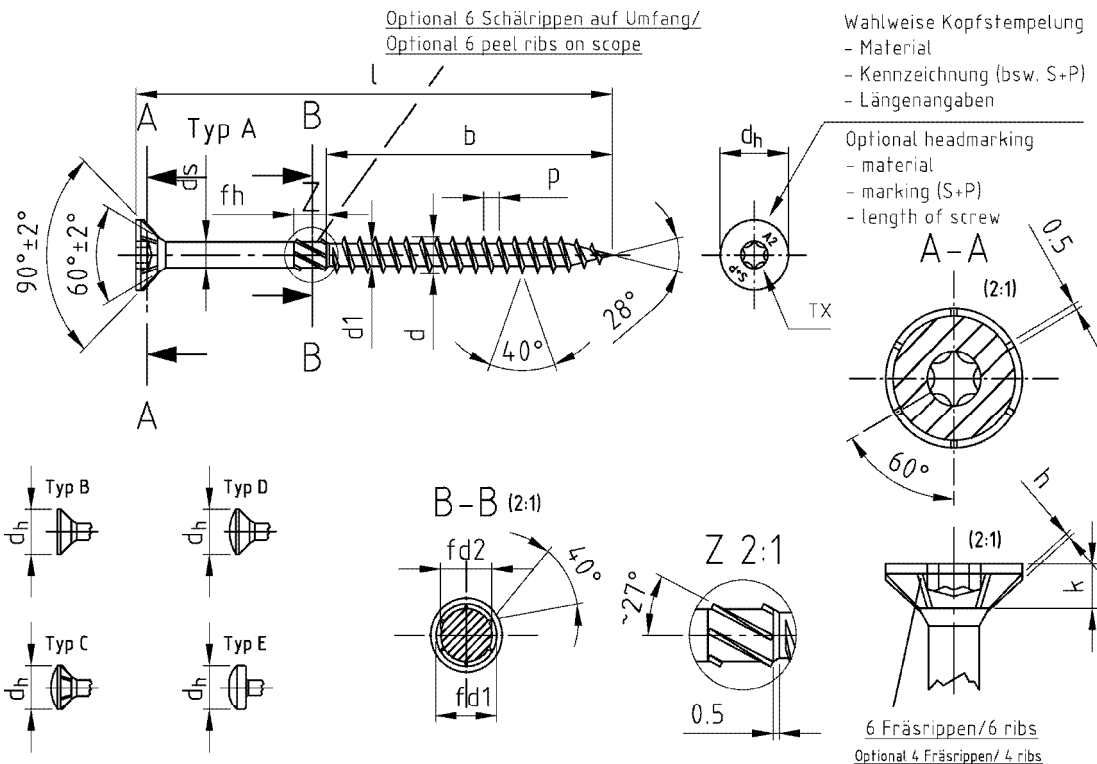

Mit fließendem Übergang vom Gewinde zum Schaft/ with floating crossing between shank and thread

Bezeichnung	SP-HBS/ Seko-Holzbauschrauben mit verstärktem Kopf, 6 Fräsrippen										
Description	SP-HBS/ Double countersunk head timber screws, 6 ribs under the head										
Nennmaß/ Nominal dia.	d	d1	dh	ds	k	p	pz	TX	h	fd1	fd2
∅ 3,0	3,0 -0,15	2,0 -0,15	6,0 -0,4	2,15 ±0,05	1,9 -0,3	1,35 ±10%	1	10	0,3	2,90 -0,15	1,75 -0,15
∅ 3,2	3,2 -0,15	2,1 -0,15	6,5 -0,4	2,3 ±0,05	2,0 -0,3	1,45 ±10%	1	10	0,3	3,15 -0,15	1,85 -0,15
∅ 3,5	3,5 -0,3	2,4 -0,3	7,0 -0,4	2,5 ±0,05	2,1 -0,3	1,6 ±10%	2	10/15	0,3	3,45 -0,25	2,4 -0,15
∅ 4,0	4,0 -0,3	2,6 -0,3	8,0 -0,5	2,84 ±0,05	2,5 -0,4	1,8 ±10%	2	15/20	0,5	3,70 -0,25	2,7 -0,15
∅ 4,5	4,5 -0,3	2,8 -0,3	9,0 -0,5	3,11 ±0,05	2,7 -0,4	2,0 ±10%	2	20/25	0,5	3,95 -0,25	2,9 -0,15
∅ 5,0	5,0 -0,3	3,0 -0,3	10,0 -0,5	3,54 ±0,05	3,0 -0,5	2,2 ±10%	2	20/25	0,5	4,2 -0,3	3,5 -0,15
∅ 6,0	6,0 -0,3	3,7 -0,3	12,0 -0,5	4,25 ±0,05	3,6 -0,5	2,6 ±10%	3	25/30	0,5	5,1 -0,3	4,3 -0,25
∅ 8,0	8,0 +0,2/-0,3	5,5 -0,5	15,0 -1,0	6,0 ±0,1	4,1 -0,5	3,6 ±10%	-	40	0,5	7,3 -0,3	5,75 -0,25
∅ 10,0	10,0 +0,2/-0,4	6,5 -0,5	19,0 -1,0	7,0 ±0,1	4,7 -0,5	4,6 ±10%	-	40	0,5	8,8 -0,3	6,75 -0,25

l -1/2 IT17	20	25	30	35	40	45	50	55	60	65	70	75	80	90	100	120-160	180-300	300-400
∅ 3,0 b ±1	12	18	18	24	24	30	30	-	-	-	-	-	-	-	-	-	-	-
∅ 3,2 b ±1	12	18	18	24	24	30	30	36	36	-	-	-	-	-	-	-	-	-
∅ 3,5 b ±1	12	18	18	24	24	30	30	36	-	-	-	-	-	-	-	-	-	-
∅ 4,0 b ±1	-	18	18	24	24	30	30	36	36	42	42	48	48	-	-	-	-	-
∅ 4,5 b ±1	-	-	18	24	24	30	30	36	36	42	42	48	48	54	60	-	-	-
∅ 5,0 b ±1	-	-	20	24	24	30	30	36	36	42	42	48	48	54	60	70	-	-
∅ 6,0 b ±1	-	-	-	24	24	30	30	36	36	42	42	48	48	54	70	70	70	-
∅ 8,0 b ±1	-	-	-	-	32	37	47	50	50	50	50	50	50	60	80	80	80	80
∅ 10,0 b ±1	-	-	-	-	-	-	-	50	55	55	55	55	55	55	80	105	105	105
fh	4,0 -0,2					6,0 -0,2					12,0 -0,6							

S+P screws

SP-HBS  
Double countersunk head timber screw

Annex 4.1

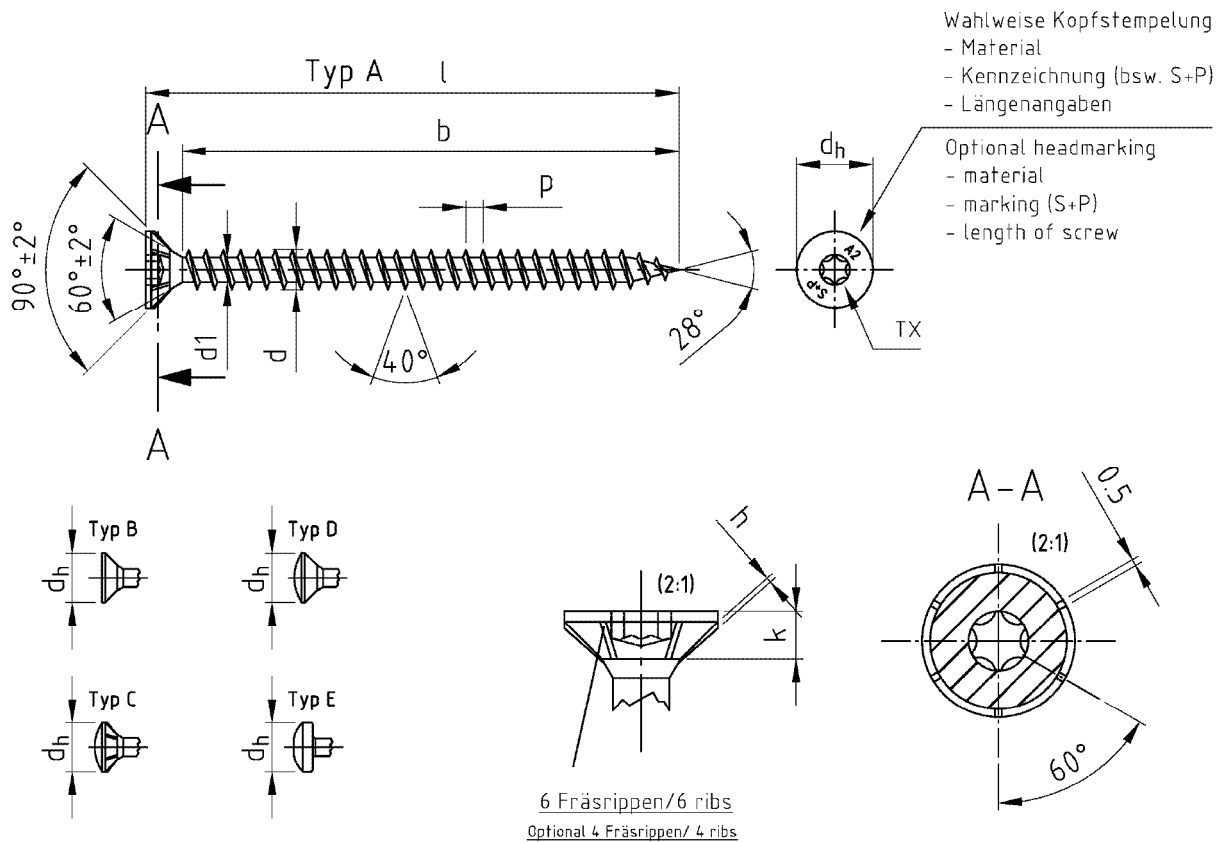

Bezeichnung	SP-HBS/ Seko-Holzbauschrauben mit verstärktem Kopf, 6 Fräsrippen, Vollgewinde							
Description	SP-HBS/ Double countersunk head timber screws, 6 ribs under the head, full thread							
Nennmaß/ Nominal dia.	d	d1	dh	k	p	pz	TX	h
ø 3,0	3,0 -0,15	2,0 -0,15	6,0 -0,4	1,9 -0,3	1,35 ±10%	1	10	0,3
ø 3,2	3,2 -0,15	2,1 -0,15	6,5 -0,4	2,0 -0,3	1,45 ±10%	1	10	0,3
ø 3,5	3,5 -0,3	2,4 -0,3	7,0 -0,4	2,1 -0,3	1,6 ±10%	2	10/15	0,3
ø 4,0	4,0 -0,3	2,6 -0,3	8,0 -0,5	2,5 -0,4	1,8 ±10%	2	15/20	0,5
ø 4,5	4,5 -0,3	2,8 -0,3	9,0 -0,5	2,7 -0,4	2,0 ±10%	2	20/25	0,5
ø 5,0	5,0 -0,3	3,0 -0,3	10,0 -0,5	3,0 -0,5	2,2 ±10%	2	20/25	0,5
ø 6,0	6,0 -0,3	3,7 -0,3	12,0 -0,5	3,6 -0,5	2,6 ±10%	3	25/30	0,5

Nennmaß/ Nominal dia.	ø 3,0	ø 3,2	ø 3,5	ø 4,0	ø 4,5	ø 5,0	ø 6,0
l min. ±1	18	19	19	23	23	28	36
l max. ±1	45	40	50	80	100	100	110
b ±1	min. /+ k	16	16	16	20	25	30
	max. /+ k	40	36	45	75	90	100

Andere Schraubenlängen im Bereich  $L_{min} \leq L \leq L_{max}$  sind zulässig / Others screws lengths with  $L_{min} \leq L \leq L_{max}$  are allowed

S+P screws

SP-HBS  
Double countersunk head timber screw, fully threaded

Annex 4.2

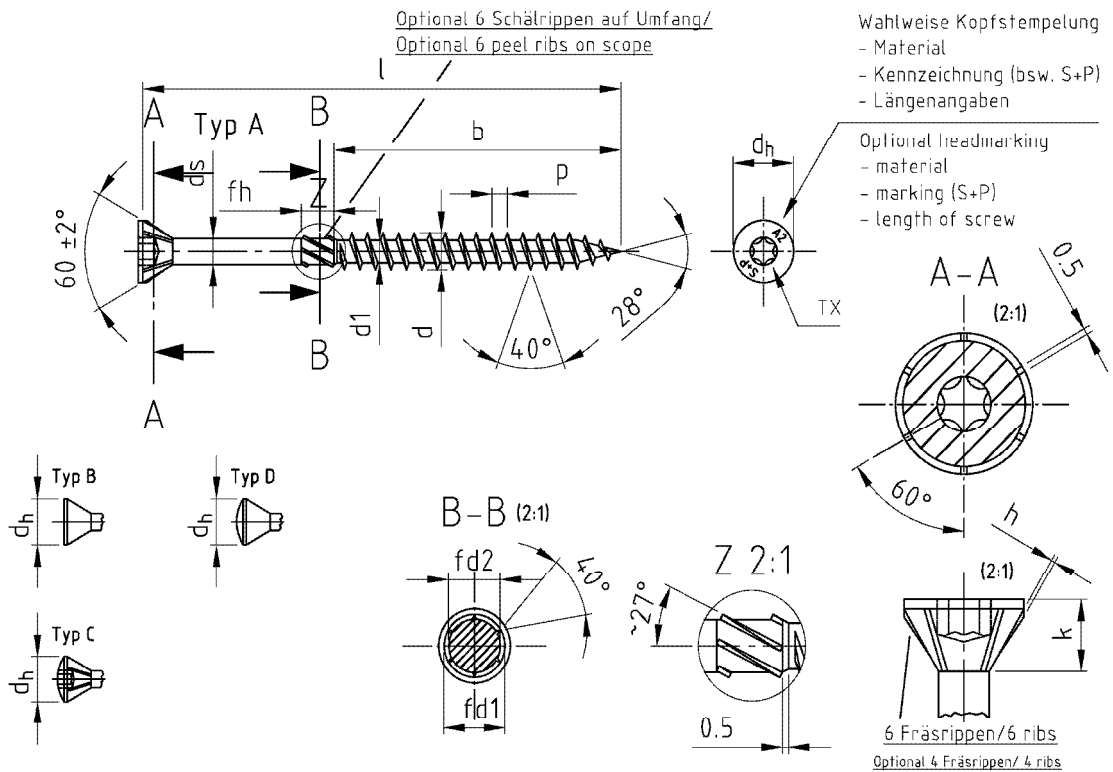

Mit fließendem Übergang vom Gewinde zum Schaft/ with floating crossing between shank and thread

Bezeichnung	SP-HBS-60°/ Seko-Holzbauschrauben mit Innensechsrund, 6 Fräsrippen, 60° Kopf										
Description	SP-HBS-60°/ Countersunk head woodscrews, six lobe drive, 6 ribs under the head, 60° head										
Nennmaß/ Nominal dia.	d	d1	dh	ds	k	p	TX	h	fd1	fd2	
∅ 3,0	3,0 -0,15	2,0 -0,15	4,5 -0,4	2,15 ±0,05	1,8 ±0,5	1,35 ±10%	10	0,3	2,90 -0,15	1,75 -0,15	
∅ 3,2	3,2 -0,15	2,1 -0,15	5,0 -0,4	2,3 ±0,05	2,0 ±0,5	1,45 ±10%	10	0,3	3,15 -0,15	1,85 -0,15	
∅ 3,5	3,5 -0,3	2,4 -0,3	5,5 -0,4	2,5 ±0,05	2,2 ±0,5	1,6 ±10%	10	0,3	3,45 -0,25	2,4 -0,15	
∅ 4,0	4,0 -0,3	2,6 -0,3	6,0 -0,5	2,84 ±0,05	2,75 ±0,5	1,8 ±10%	15/20	0,5	3,70 -0,25	2,7 -0,15	
∅ 4,5	4,5 -0,3	2,8 -0,3	7,0 -0,5	3,11 ±0,05	3,35 ±0,5	2,0 ±10%	20/25	0,5	3,95 -0,25	2,9 -0,15	
∅ 5,0	5,0 -0,3	3,0 -0,3	7,5 -0,5	3,54 ±0,05	3,45 ±0,5	2,2 ±10%	20/25	0,5	4,2 -0,3	3,5 -0,15	
∅ 6,0	6,0 -0,3	3,7 -0,3	11,0 -0,5	4,25 ±0,05	5,85 ±0,5	2,6 ±10%	25/30	0,5	5,1 -0,3	4,3 -0,25	
∅ 8,0	8,0 +0,2/-0,3	5,5 -0,5	14,0 -1,0	6,0 ±0,1	6,95 ±0,5	3,6 ±10%	40	0,5	7,3 -0,3	5,75 -0,25	
∅ 10,0	10,0 +0,2/-0,4	6,5 -0,5	16,0 -1,0	7,0 ±0,1	7,8 ±0,5	4,6 ±10%	40	0,5	8,8 -0,3	6,75 -0,25	

l -1/2 IT17	25	30	35	40	45	50	55	60	65	70	75	80	90	100	120-160	180-300	300-400
∅ 3,0 b ±1	18	18	24	24	30	30	-	-	-	-	-	-	-	-	-	-	-
∅ 3,2 b ±1	18	18	24	24	30	30	36	36	-	-	-	-	-	-	-	-	-
∅ 3,5 b ±1	18	18	24	24	30	30	36	-	-	-	-	-	-	-	-	-	-
∅ 4,0 b ±1	18	18	24	24	30	30	36	36	42	42	48	48	-	-	-	-	-
∅ 4,5 b ±1	-	18	24	24	30	30	36	36	42	42	48	48	54	60	-	-	-
∅ 5,0 b ±1	-	20	24	24	30	30	36	36	42	42	48	48	54	60	70	-	-
∅ 6,0 b ±1	-	-	24	24	30	30	36	36	42	42	48	48	54	70	70	70	-
∅ 8,0 b ±1	-	-	-	32	37	47	50	50	50	50	50	50	60	80	80	80	80
∅ 10,0 b ±1	-	-	-	-	-	-	-	50	55	55	55	55	55	55	80	105	105
fh	4,0 -0,2			6,0 -0,2						12,0 -0,6							

S+P screws

SP-HBS-60°  
Countersunk head timber screw, 60° head

Annex 4.3

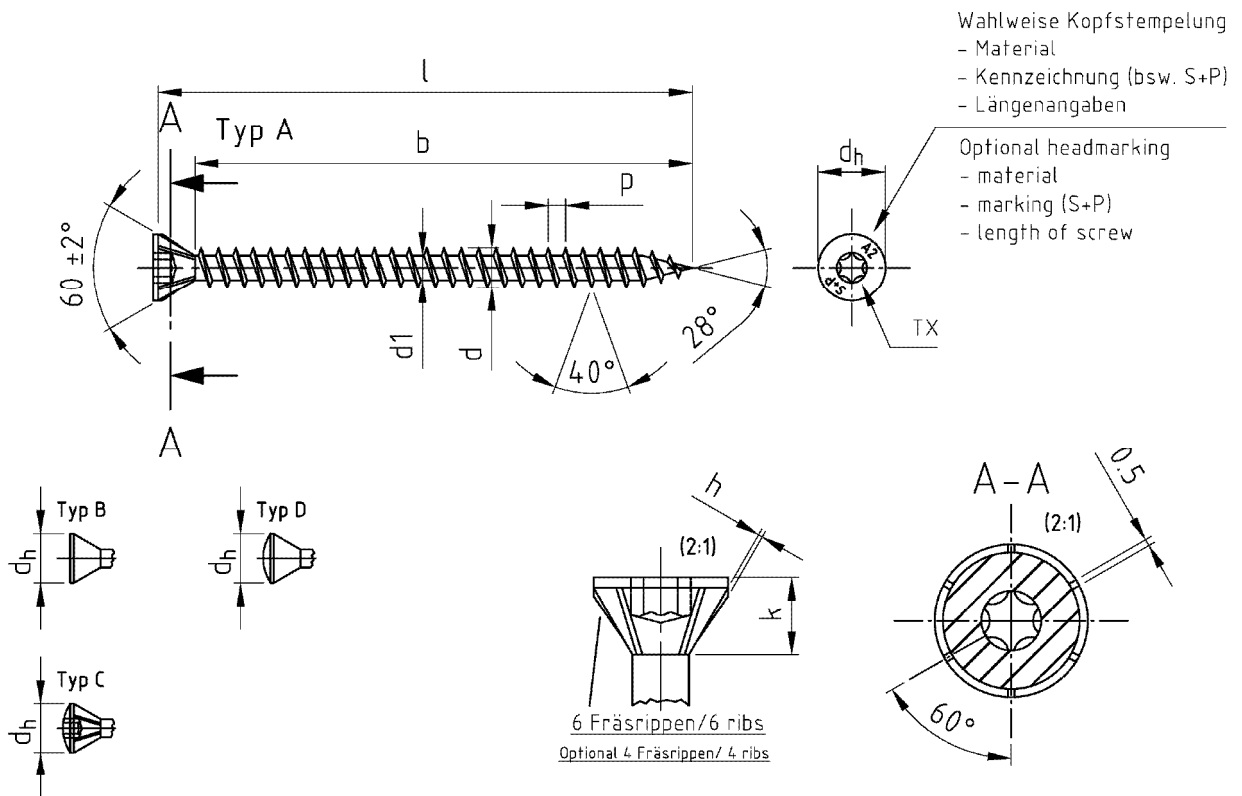

Bezeichnung	SP-HBS-60°/ Seko-Holzbauschrauben mit Innensechsrund, 6 Fräsrippen, 60° Kopf, Vollgewinde						
Description	SP-HBS-60°/ Countersunk head woodscrews, six lobe drive, 6 ribs under the head, 60° head, full thread						
Nennmaß/ Nominal dia.	d	d1	dh	k	p	TX	h
∅ 3,0	3,0 -0,15	2,0 -0,15	4,5 -0,4	1,8 ±0,5	1,35 ±10%	10	0,3
∅ 3,2	3,2 -0,15	2,1 -0,15	5,0 -0,4	2,0 ±0,5	1,45 ±10%	10	0,3
∅ 3,5	3,5 -0,3	2,4 -0,3	5,5 -0,4	2,2 ±0,5	1,6 ±10%	10	0,3
∅ 4,0	4,0 -0,3	2,6 -0,3	6,0 -0,5	2,75 ±0,5	1,8 ±10%	15/20	0,5
∅ 4,5	4,5 -0,3	2,8 -0,3	7,0 -0,5	3,35 ±0,5	2,0 ±10%	20/25	0,5
∅ 5,0	5,0 -0,3	3,0 -0,3	7,5 -0,5	3,45 ±0,5	2,2 ±10%	20/25	0,5
∅ 6,0	6,0 -0,3	3,7 -0,3	11,0 -0,5	5,85 ±0,5	2,6 ±10%	25/30	0,5

Nennmaß/ Nominal dia.	∅ 3,0	∅ 3,2	∅ 3,5	∅ 4,0	∅ 4,5	∅ 5,0	∅ 6,0
l min. ±1	18	19	19	23	23	28	36
l max. ±1	45	40	50	80	100	100	110
b ±1	min. /+ k	16	16	16	20	25	30
	max. /+ k	40	36	45	75	90	100

Andere Schraubenlängen im Bereich  $L_{min} \leq L \leq L_{max}$  sind zulässig / Others screws lengths with  $L_{min} \leq L \leq L_{max}$  are allowed

S+P screws

SP-HBS-60°  
Countersunk head timber screw, fully threaded, 60° head

Annex 4.4

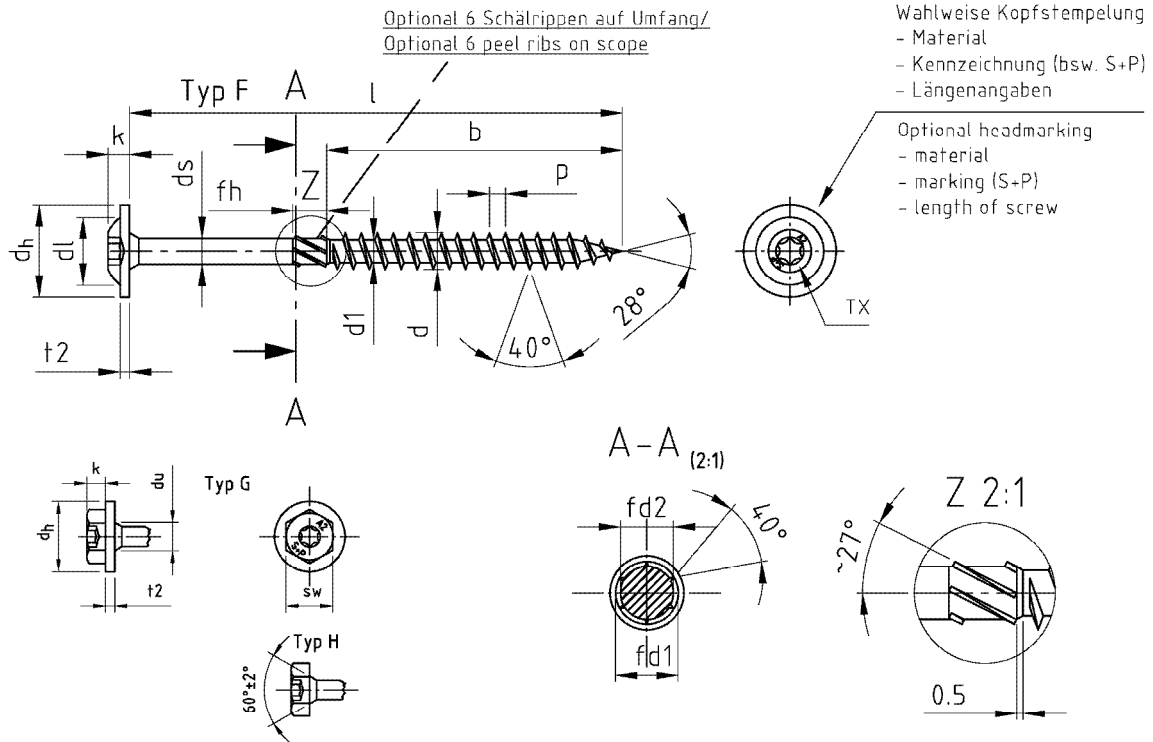

Bezeichnung	SP-HBS/ Tellerkopf-Holzbauschrauben mit Teilgewinde											
Description	SP-HBS/ Pan washer head timber screws with partial thread											
Nennmaß/ Nominal dia.	d	d1	dh	dl	ds	k	P	t2	TX	sw	fd1	fd2
ø 3,0	3,0 -0,15	2,0 -0,15	9,0 ±1,0	4,5	2,15 ±0,05	2,2 ±0,4	1,35 ±10%	1,3 -0,5	10	3	2,90 -0,15	1,75 -0,15
ø 3,2	3,2 -0,15	2,1 -0,15	10,0 ±1,0	5,0	2,3 ±0,05	2,5 ±0,4	1,45 ±10%	1,4 -0,5	10	4	3,15 -0,15	1,85 -0,15
ø 3,5	3,5 -0,3	2,4 -0,3	11,0 ±1,0	6,0	2,5 ±0,05	2,7 ±0,4	1,6 ±10%	1,5 -0,5	10/15	5	3,45 -0,25	2,4 -0,15
ø 4,0	4,0 -0,3	2,6 -0,3	12,0 ±1,0	7,0	2,84 ±0,05	3,0 ±0,4	1,8 ±10%	1,5 -0,5	15/20	6	3,70 -0,25	2,7 -0,15
ø 4,5	4,5 -0,3	2,8 -0,3	13,0 ±1,0	8,0	3,11 ±0,05	3,2 ±0,4	2,0 ±10%	1,5 -0,5	20/25	7	3,95 -0,25	2,9 -0,15
ø 5,0	5,0 -0,3	3,0 -0,3	14,0 ±1,0	9,0	3,54 ±0,05	3,5 ±0,4	2,2 ±10%	1,5 -0,5	20/25	8	4,2 -0,3	3,5 -0,15
ø 6,0	6,0 -0,3	3,7 -0,3	15,0 ±1,0	11,0	4,25 ±0,05	3,8 ±0,4	2,6 ±10%	2,0 -0,5	25/30	10	5,1 -0,3	4,3 -0,25
ø 8,0	8,0 +0,2/-0,3	5,5 -0,5	20,0 -1,0	15,0	6,0 ±0,1	4,6 ±0,4	3,6 ±10%	2,0 -0,5	40	12	7,3 -0,3	5,75 -0,25
ø 10,0	10,0 +0,2/-0,4	6,5 -0,5	25,0 -1,0	20,0	7,0 ±0,1	5,0 ±0,4	4,6 ±10%	2,0 -0,5	40	15	8,8 -0,3	6,75 -0,25

l - 1/2 IT17	25	30	35	40	45	50	55	60	65	70	75	80	90	100	120-160	180-300	300-400
ø 3,0 b ±1	18	18	24	24	30	30	-	-	-	-	-	-	-	-	-	-	-
ø 3,2 b ±1	18	18	24	24	30	30	36	36	-	-	-	-	-	-	-	-	-
ø 3,5 b ±1	18	18	24	24	30	30	36	-	-	-	-	-	-	-	-	-	-
ø 4,0 b ±1	18	18	24	24	30	30	36	36	42	42	-	-	-	-	-	-	-
ø 4,5 b ±1	-	18	24	24	30	30	36	36	42	42	48	48	-	-	-	-	-
ø 5,0 b ±1	-	20	24	24	30	30	36	36	42	42	48	48	54	60	70	-	-
ø 6,0 b ±1	-	-	24	24	30	30	36	36	42	42	48	48	54	70	70	70	-
ø 8,0 b ±1	-	-	-	32	37	47	50	50	50	50	50	72	80	80	80	80	80
ø 10,0 b ±1	-	-	-	-	-	-	50	55	55	55	55	55	55	55	80	105	105
fh	4,0 -0,2				6,0 -0,2				12,0 -0,6								

S+P screws

SP-HBS  
Pan washer head timber screw

Annex 4.5

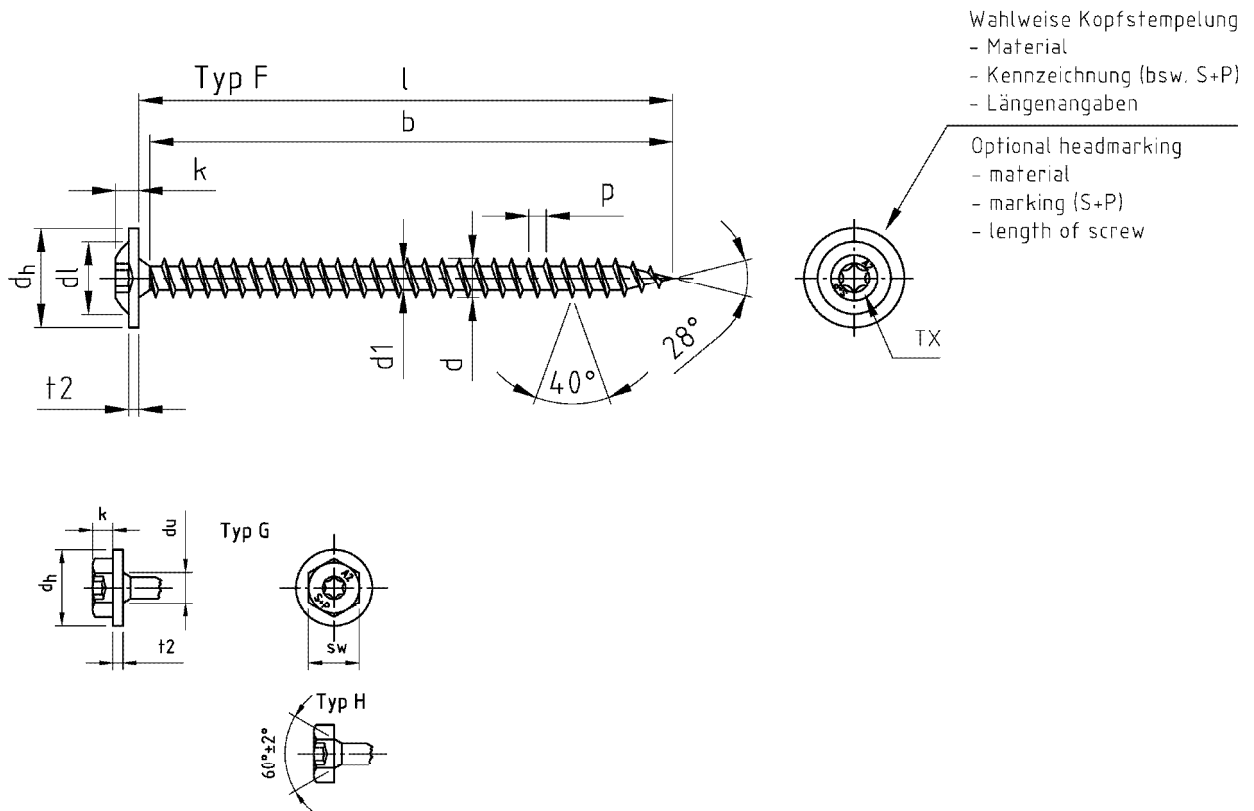

Bezeichnung	SP-HBS/ Tellerkopf-Holzbohrschrauben mit Vollgewinde								
Description	SP-HBS/ Pan washer head timber screws with full thread								
Nennmaß/ Nominal dia.	d	d1	dh	d1	k	p	t2	TX	sw
∅ 3,0	3,0 -0,15	2,0 -0,15	9,0 ±1,0	4,5	2,2 ±0,4	1,35 ±10%	1,3 -0,5	10	3
∅ 3,2	3,2 -0,15	2,1 -0,15	10,0 ±1,0	5,0	2,5 ±0,4	1,45 ±10%	1,4 -0,5	10	4
∅ 3,5	3,5 -0,3	2,4 -0,3	11,0 ±1,0	6,0	2,7 ±0,4	1,6 ±10%	1,5 -0,5	10/15	5
∅ 4,0	4,0 -0,3	2,6 -0,3	12,0 ±1,0	7,0	3,0 ±0,4	1,8 ±10%	1,5 -0,5	15/20	6
∅ 4,5	4,5 -0,3	2,8 -0,3	13,0 ±1,0	8,0	3,2 ±0,4	2,0 ±10%	1,5 -0,5	20/25	7
∅ 5,0	5,0 -0,3	3,0 -0,3	14,0 ±1,0	9,0	3,5 ±0,4	2,2 ±10%	1,5 -0,5	20/25	8
∅ 6,0	6,0 -0,3	3,7 -0,3	15,0 ±1,0	11,0	3,8 ±0,4	2,6 ±10%	2,0 -0,5	25/30	10

Nennmaß/ Nominal dia.	∅ 3,0	∅ 3,2	∅ 3,5	∅ 4,0	∅ 4,5	∅ 5,0	∅ 6,0
l min. ±1	18	19	19	23	23	28	36
l max. ±1	45	40	50	80	100	100	110
b ±1	min. /+ k	16	16	16	20	25	30
	max. /+ k	40	36	45	75	90	100

Andere Schraubenlängen im Bereich  $L_{min} \leq L \leq L_{max}$  sind zulässig / Others screws lengths with  $L_{min} \leq L \leq max$  are allowed

S+P screws

SP-HBS  
Pan washer head timber screw, fully threaded

Annex 4.6

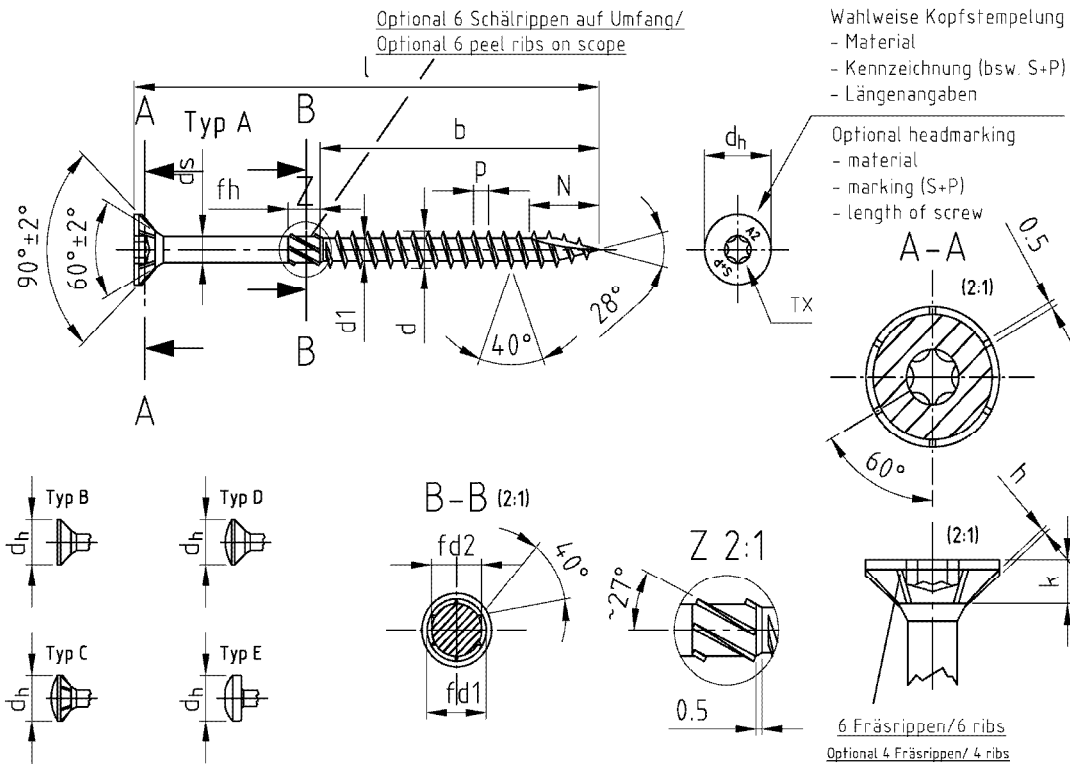

Mit fließendem Übergang vom Gewinde zum Schaft / with floating crossing between shank and thread

Bezeichnung	SP-HBS/ Seko-Holzbohrschrauben mit verstärktem Kopf, 6 Fräsrippen, Schneidkerbe											
Description	SP-HBS/ Double countersunk head timber screws, 6 ribs under the head, cutting kerf											
Nennmaß/ Nominal dia.	d	d1	dh	ds	k	p	pz	TX	h	fd1	fd2	N
ø 3,0	3,0 -0,15	2,0 -0,15	6,0 -0,4	2,15 ±0,05	1,9 -0,3	1,35 ±10%	1	10	0,3	2,90 -0,15	1,75 -0,15	5,5 ±0,5
ø 3,2	3,2 -0,15	2,1 -0,15	6,5 -0,4	2,3 ±0,05	2,0 -0,3	1,45 ±10%	1	10	0,3	3,15 -0,15	1,85 -0,15	6,5 ±0,5
ø 3,5	3,5 -0,3	2,4 -0,3	7,0 -0,4	2,5 ±0,05	2,1 -0,3	1,6 ±10%	2	10/15	0,3	3,45 -0,25	2,4 -0,15	7,0 ±0,5
ø 4,0	4,0 -0,3	2,6 -0,3	8,0 -0,5	2,84 ±0,05	2,5 -0,4	1,8 ±10%	2	15/20	0,5	3,70 -0,25	2,7 -0,15	7,5 ±0,5
ø 4,5	4,5 -0,3	2,8 -0,3	9,0 -0,5	3,11 ±0,05	2,7 -0,4	2,0 ±10%	2	20/25	0,5	3,95 -0,25	2,9 -0,15	8,5 ±0,5
ø 5,0	5,0 -0,3	3,0 -0,3	10,0 -0,5	3,54 ±0,05	3,0 -0,5	2,2 ±10%	2	20/25	0,5	4,2 -0,3	3,5 -0,15	9,5 ±0,5
ø 6,0	6,0 -0,3	3,7 -0,3	12,0 -0,5	4,25 ±0,05	3,6 -0,5	2,6 ±10%	3	25/30	0,5	5,1 -0,3	4,3 -0,25	11,0 ±1,0
ø 8,0	8,0 +0,2/-0,3	5,5 -0,5	15,0 -1,0	6,0 ±0,1	4,1 -0,5	3,6 ±10%	-	40	0,5	7,3 -0,3	5,75 -0,25	13,0 ±1,0
ø 10,0	10,0 +0,2/-0,4	6,5 -0,5	19,0 -1,0	7,0 ±0,1	4,7 -0,5	4,6 ±10%	-	40	0,5	8,8 -0,3	6,75 -0,25	15,0 ±1,0

l -1/2 IT17	25	30	35	40	45	50	55	60	65	70	75	80	90	100	120-160	180-300	300-400
ø 3,0 b ±1	18	18	24	24	30	30	-	-	-	-	-	-	-	-	-	-	-
ø 3,2 b ±1	18	18	24	24	30	30	36	36	-	-	-	-	-	-	-	-	-
ø 3,5 b ±1	18	18	24	24	30	30	36	-	-	-	-	-	-	-	-	-	-
ø 4,0 b ±1	18	18	24	24	30	30	36	36	36	42	48	48	-	-	-	-	-
ø 4,5 b ±1	-	18	24	24	30	30	36	36	36	42	48	48	54	60	-	-	-
ø 5,0 b ±1	-	20	24	24	30	30	36	36	36	42	48	48	54	60	70	-	-
ø 6,0 b ±1	-	-	24	24	30	30	36	36	36	42	48	48	54	70	70	70	-
ø 8,0 b ±1	-	-	-	32	37	47	50	50	50	50	50	50	60	80	80	80	80
ø 10,0 b ±1	-	-	-	-	-	-	50	55	55	55	55	55	55	55	80	105	105
fh	4,0 -0,2				6,0 -0,2				12,0 -0,6								

S+P screws

SP-HBS  
Double countersunk head timber screw

Annex 4.7

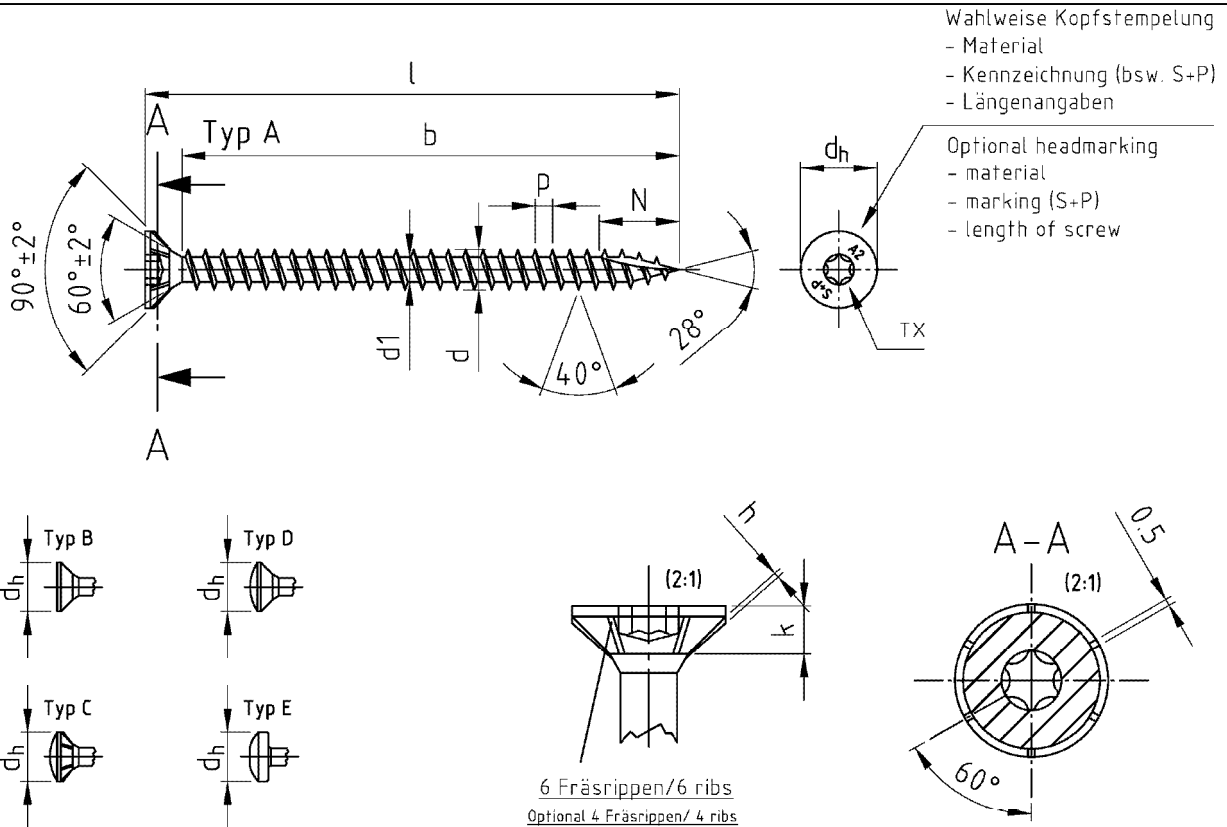

Bezeichnung	SP-HBS/ Seko-Holzbauschrauben mit verstärktem Kopf, 6 Fräsrippen, Schneidkerbe, Vollgewinde									
Description	SP-HBS/ Double countersank head timber screws, 6 ribs under the head, cutting point, full thread									
Nennmaß/ Nominal dia.	d	d1	dh	k	p	pz	TX	h	N	
∅ 3,0	3,0 -0,15	2,0 -0,15	6,0 -0,4	1,9 -0,3	1,35 ±10%	1	10	0,3	5,5 ±0,5	
∅ 3,2	3,2 -0,15	2,1 -0,15	6,5 -0,4	2,0 -0,3	1,45 ±10%	1	10	0,3	6,5 ±0,5	
∅ 3,5	3,5 -0,3	2,4 -0,3	7,0 -0,4	2,1 -0,3	1,6 ±10%	2	10/15	0,3	7,0 ±0,5	
∅ 4,0	4,0 -0,3	2,6 -0,3	8,0 -0,5	2,5 -0,4	1,8 ±10%	2	15/20	0,5	7,5 ±0,5	
∅ 4,5	4,5 -0,3	2,8 -0,3	9,0 -0,5	2,7 -0,4	2,0 ±10%	2	20/25	0,5	8,5 ±0,5	
∅ 5,0	5,0 -0,3	3,0 -0,3	10,0 -0,5	3,0 -0,5	2,2 ±10%	2	20/25	0,5	9,5 ±0,5	
∅ 6,0	6,0 -0,3	3,7 -0,3	12,0 -0,5	3,6 -0,5	2,6 ±10%	3	25/30	0,5	11,0 ±1,0	

Nennmaß/ Nominal dia.	∅ 3,0	∅ 3,2	∅ 3,5	∅ 4,0	∅ 4,5	∅ 5,0	∅ 6,0
l min. ±1	18	19	19	23	23	28	36
l max. ±1	45	40	50	80	100	100	110
b ±1	min. /+ k	16	16	16	20	25	30
	max. /+ k	40	36	45	75	90	100

Andere Schraubentlängen im Bereich  $l_{min} \leq L \leq l_{max}$  sind zulässig / Others screws lengths with  $l_{min} \leq L \leq l_{max}$  are allowed

S+P screws

SP-HBS  
Countersunk head timber screw, fully threaded

Annex 4.8

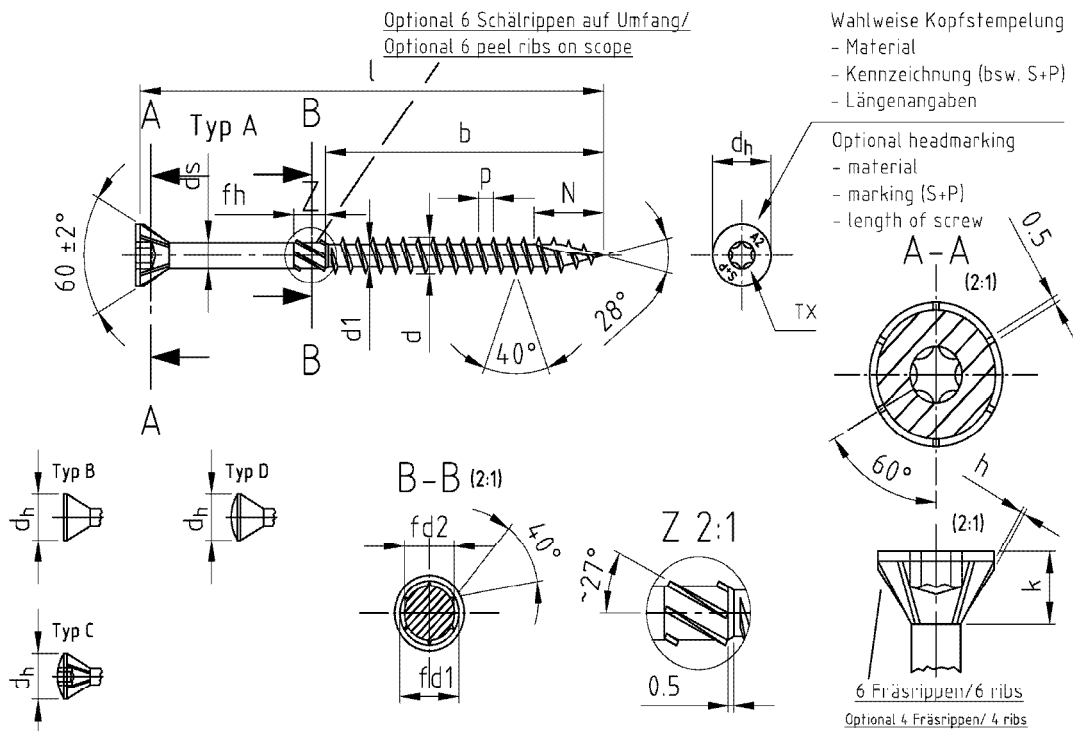

Bezeichnung	SP-HBS-60°/ Seko-Holzbauschrauben mit Innensechsrund, 6 Fräsrippen, Schneidkerbe										
Description	SP-HBS-60°/ Countersunk head woodscrews, six lobe drive, 6 ribs under the head, cutting point										
Nennmaß/ Nominal dia.	d	d1	dh	ds	k	p	TX	h	fd1	fd2	N
ø 3,0	3,0 -0,15	2,0 -0,15	4,5 -0,4	2,15 ±0,05	1,8 ±0,5	1,35 ±10%	10	0,3	2,90 -0,15	1,75 -0,15	5,5 ±0,5
ø 3,2	3,2 -0,15	2,1 -0,15	5,0 -0,4	2,3 ±0,05	2,0 ±0,5	1,45 ±10%	10	0,3	3,15 -0,15	1,85 -0,15	6,5 ±0,5
ø 3,5	3,5 -0,3	2,4 -0,3	5,5 -0,4	2,5 ±0,05	2,2 ±0,5	1,6 ±10%	10	0,3	3,45 -0,25	2,4 -0,15	7,0 ±0,5
ø 4,0	4,0 -0,3	2,6 -0,3	6,0 -0,5	2,84 ±0,05	2,75 ±0,5	1,8 ±10%	15/20	0,5	3,70 -0,25	2,7 -0,15	7,5 ±0,5
ø 4,5	4,5 -0,3	2,8 -0,3	7,0 -0,5	3,11 ±0,05	3,35 ±0,5	2,0 ±10%	20/25	0,5	3,95 -0,25	2,9 -0,15	8,5 ±0,5
ø 5,0	5,0 -0,3	3,0 -0,3	7,5 -0,5	3,54 ±0,05	3,45 ±0,5	2,2 ±10%	20/25	0,5	4,2 -0,3	3,5 -0,15	9,5 ±0,5
ø 6,0	6,0 -0,3	3,7 -0,3	11,0 -0,5	4,25 ±0,05	5,85 ±0,5	2,6 ±10%	25/30	0,5	5,1 -0,3	4,3 -0,25	11,0 ±1,0
ø 8,0	8,0 +0,2/-0,3	5,5 -0,5	14,0 -1,0	6,0 ±0,1	6,95 ±0,5	3,6 ±10%	40	0,5	7,3 -0,3	5,75 -0,25	13,0 ±1,0
ø 10,0	10,0 +0,2/-0,4	6,5 -0,5	16,0 -1,0	7,0 ±0,1	7,8 ±0,5	4,6 ±10%	40	0,5	8,8 -0,3	6,75 -0,25	15,0 ±1,0

l -1/2 IT17	25	30	35	40	45	50	55	60	65	70	75	80	90	100	110-160	180-300	300-400
ø 3,0 b ±1	18	18	24	24	30	30	-	-	-	-	-	-	-	-	-	-	-
ø 3,2 b ±1	18	18	24	24	30	30	36	36	-	-	-	-	-	-	-	-	-
ø 3,5 b ±1	18	18	24	24	30	30	36	-	-	-	-	-	-	-	-	-	-
ø 4,0 b ±1	18	18	24	24	30	30	36	36	36	42	48	48	-	-	-	-	-
ø 4,5 b ±1	-	18	24	24	30	30	36	36	36	42	48	48	54	60	-	-	-
ø 5,0 b ±1	-	20	24	24	30	30	36	36	36	42	48	48	54	60	70	-	-
ø 6,0 b ±1	-	-	24	24	30	30	36	36	36	42	48	48	54	70	70	70	-
ø 8,0 b ±1	-	-	-	32	37	47	50	50	50	50	50	50	60	80	80	80	80
ø 10,0 b ±1	-	-	-	-	-	-	50	55	55	55	55	55	55	55	80	105	105
fh	4,0 -0,2				6,0 -0,2				12,0 -6,0								

S+P screws

SP-HBS-60°  
Countersunk head timber screw, 60° head

Annex 4.9

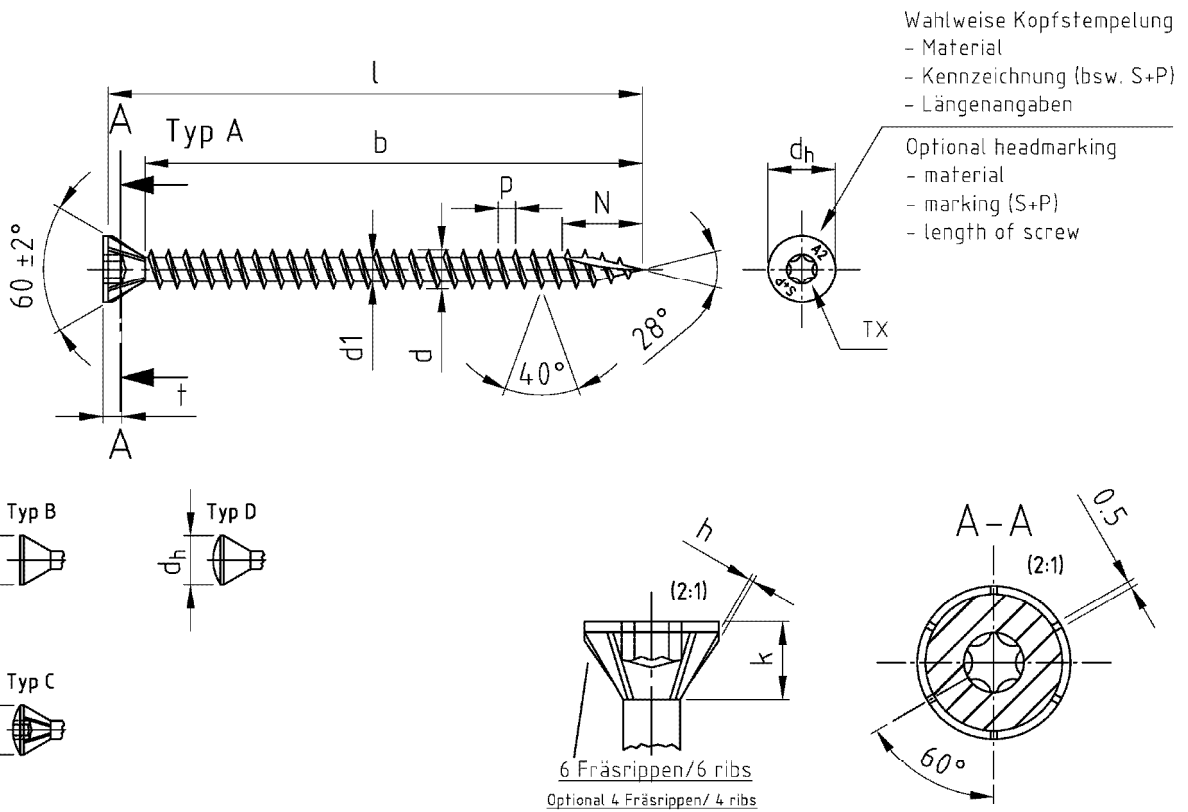

Bezeichnung	SP-HBS-60°/ Seko-Holzbauschrauben mit Innensechsrund, 6 Fräsrippen, Schneidkerbe, Vollgewinde							
Description	SP-HBS-60°/ Countersunk head woodscrews, six lobe drive, 6 ribs under the head, cutting point, full thread							
Nennmaß/ Nominal dia.	d	d1	dh	k	p	TX	h	N
ø 3,0	3,0 -0,15	2,0 -0,15	4,5 -0,4	1,8 ±0,5	1,35 ±10%	10	0,3	5,5 ±0,5
ø 3,2	3,2 -0,15	2,1 -0,15	5,0 -0,4	2,0 ±0,5	1,45 ±10%	10	0,3	6,5 ±0,5
ø 3,5	3,5 -0,3	2,4 -0,3	5,5 -0,4	2,2 ±0,5	1,6 ±10%	10	0,3	7,0 ±0,5
ø 4,0	4,0 -0,3	2,6 -0,3	6,0 -0,5	2,75 ±0,5	1,8 ±10%	15/20	0,5	7,5 ±0,5
ø 4,5	4,5 -0,3	2,8 -0,3	7,0 -0,5	3,35 ±0,5	2,0 ±10%	20/25	0,5	8,5 ±0,5
ø 5,0	5,0 -0,3	3,0 -0,3	7,5 -0,5	3,45 ±0,5	2,2 ±10%	20/25	0,5	9,5 ±0,5
ø 6,0	6,0 -0,3	3,7 -0,3	11,0 -0,5	5,85 ±0,5	2,6 ±10%	25/30	0,5	11,0 ±1,0

Nennmaß/ Nominal dia.	ø 3,0	ø 3,2	ø 3,5	ø 4,0	ø 4,5	ø 5,0	ø 6,0
l min. ±1	18	19	19	23	23	28	36
l max. ±1	45	40	50	80	100	100	110
b ±1	min. /+ k	16	16	16	20	25	30
	max. /+ k	40	36	45	75	90	100

Andere Schraubenlängen im Bereich  $L_{min} \leq L \leq L_{max}$  sind zulässig / Others screws lengths with  $L_{min} \leq L \leq max$  are allowed

S+P screws

SP-HBS-60°  
Countersunk head timber screw, fully threaded, 60° head

Annex 4.10

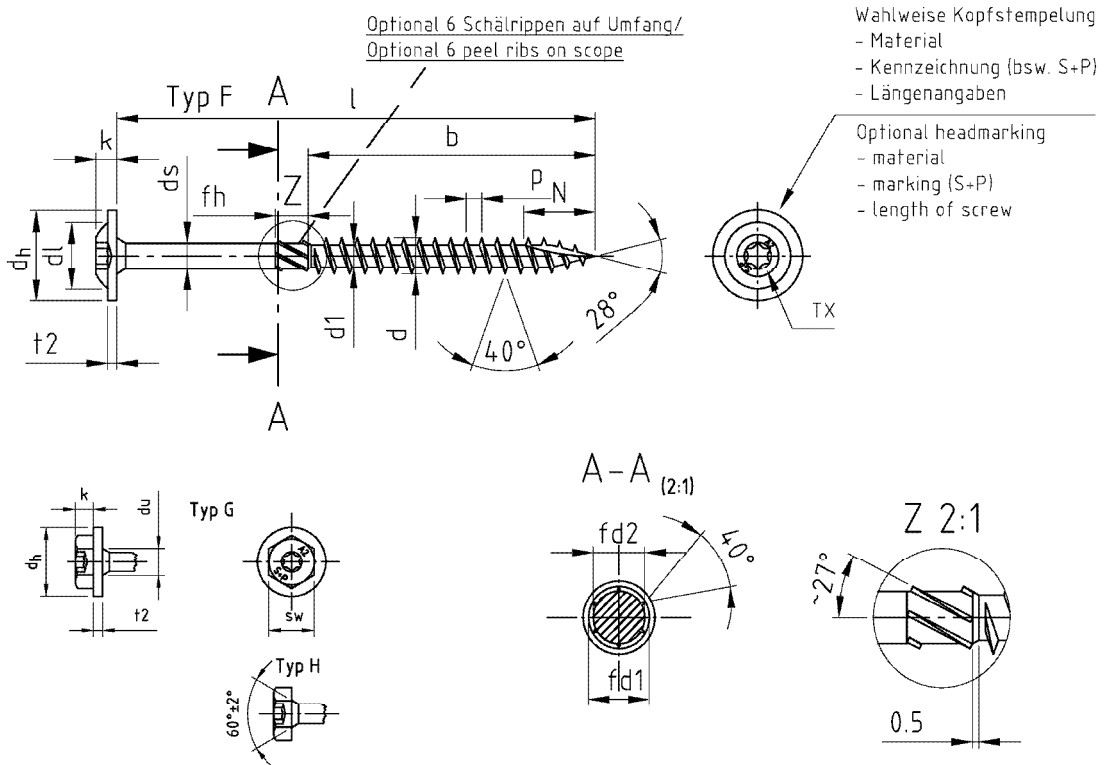

Mit fließendem Übergang vom Gewinde zum Schaft / with floating crossing between shank and thread

Bezeichnung	SP-HBS/ Tellerkopf-Holzbauschrauben mit Schnidkerbe													
Description	SP-HBS/ Pan washer head timber screws with cutting point													
Nennmaß/ Nominal dia.	d	d1	dh	dI	ds	k	p	t2	TX	sw	fd1	fd2	N	
Ø 3,0	3,0 -0,15	2,0 -0,15	9,0 ±1,0	4,5	2,15 ±0,05	2,2 ±0,4	1,38 ±10%	1,3 -0,5	10	3	2,90 -0,15	1,75 -0,15	5,5 ±0,5	
Ø 3,2	3,2 -0,15	2,1 -0,15	10,0 ±1,0	5,0	2,3 ±0,05	2,5 ±0,4	1,45 ±10%	1,4 -0,5	10	4	3,15 -0,15	1,85 -0,15	6,5 ±0,5	
Ø 3,5	3,5 -0,3	2,4 -0,3	11,0 ±1,0	6,0	2,5 ±0,05	2,7 ±0,4	1,6 ±10%	1,5 -0,5	10/15	b	3,45 -0,25	2,4 -0,15	7,0 ±0,5	
Ø 4,0	4,0 -0,3	2,6 -0,3	12,0 ±1,0	7,0	2,84 ±0,05	3,0 ±0,4	1,8 ±10%	1,5 -0,5	15/20	6	3,70 -0,25	2,7 -0,15	7,5 ±0,5	
Ø 4,5	4,5 -0,3	2,8 -0,3	13,0 ±1,0	8,0	3,11 ±0,05	3,2 ±0,4	2,0 ±10%	1,5 -0,5	20/25	7	3,95 -0,25	2,9 -0,15	8,5 ±0,5	
Ø 5,0	5,0 -0,3	3,0 -0,3	14,0 ±1,0	9,0	3,54 ±0,05	3,5 ±0,4	2,2 ±10%	1,5 -0,5	20/25	8	4,2 -0,3	3,5 -0,15	9,5 ±0,5	
Ø 6,0	6,0 -0,3	3,7 -0,3	15,0 ±1,0	11,0	4,25 ±0,05	3,8 ±0,4	2,6 ±10%	2,0 -0,5	25/30	10	5,1 -0,3	4,3 -0,25	11,0 ±1	
Ø 8,0	8,0 +0,2/-0,3	5,5 -0,5	20,0 -1,0	15,0	6,0 ±0,1	4,6 ±0,4	3,6 ±10%	2,0 -0,5	40	12	7,3 -0,3	5,75 -0,25	13,0 ±1	
Ø 10,0	10,0 +0,2/-0,4	6,5 -0,5	25,0 -1,0	20,0	7,0 ±0,1	5,0 ±0,4	4,6 ±10%	2,0 -0,5	40	15	8,8 -0,3	6,75 -0,25	15,0 ±1	

l -1/2 l (l17)	10	12	16	20	25	30	35	40	45	50	55	60	65	70	75	80	90	100	120-160	180-300	300-400	
Ø 3,0 b ±1	-	-	-	-	18	18	24	24	30	30	-	-	-	-	-	-	-	-	-	-	-	
Ø 3,2 b ±1	-	-	-	-	18	18	24	24	30	30	36	36	-	-	-	-	-	-	-	-	-	
Ø 3,5 b ±1	-	-	-	-	18	18	24	24	30	30	36	-	-	-	-	-	-	-	-	-	-	
Ø 4,0 b ±1	-	-	-	-	18	18	24	24	30	30	36	36	36	42	-	-	-	-	-	-	-	
Ø 4,5 b ±1	-	-	-	-	18	18	24	24	30	30	36	36	36	42	48	48	-	-	-	-	-	
Ø 5,0 b ±1	-	-	-	-	20	24	24	30	30	36	36	36	42	48	48	54	60	70	70	-	-	
Ø 6,0 b ±1	-	-	-	-	24	24	30	30	36	36	36	42	48	48	54	70	70	70	70	-	-	
Ø 8,0 b ±1	-	-	-	-	-	32	37	47	50	50	50	50	50	50	72	80	80	80	80	80	80	
Ø 10,0 b ±1	-	-	-	-	-	-	-	-	-	50	55	55	55	55	55	55	55	55	80	105	105	
fh	4,0 -0,2				6,0 -0,2				12,0 -0,5													

S+P screws

SP-HBS  
Pan washer head timber screw

Annex 4.11

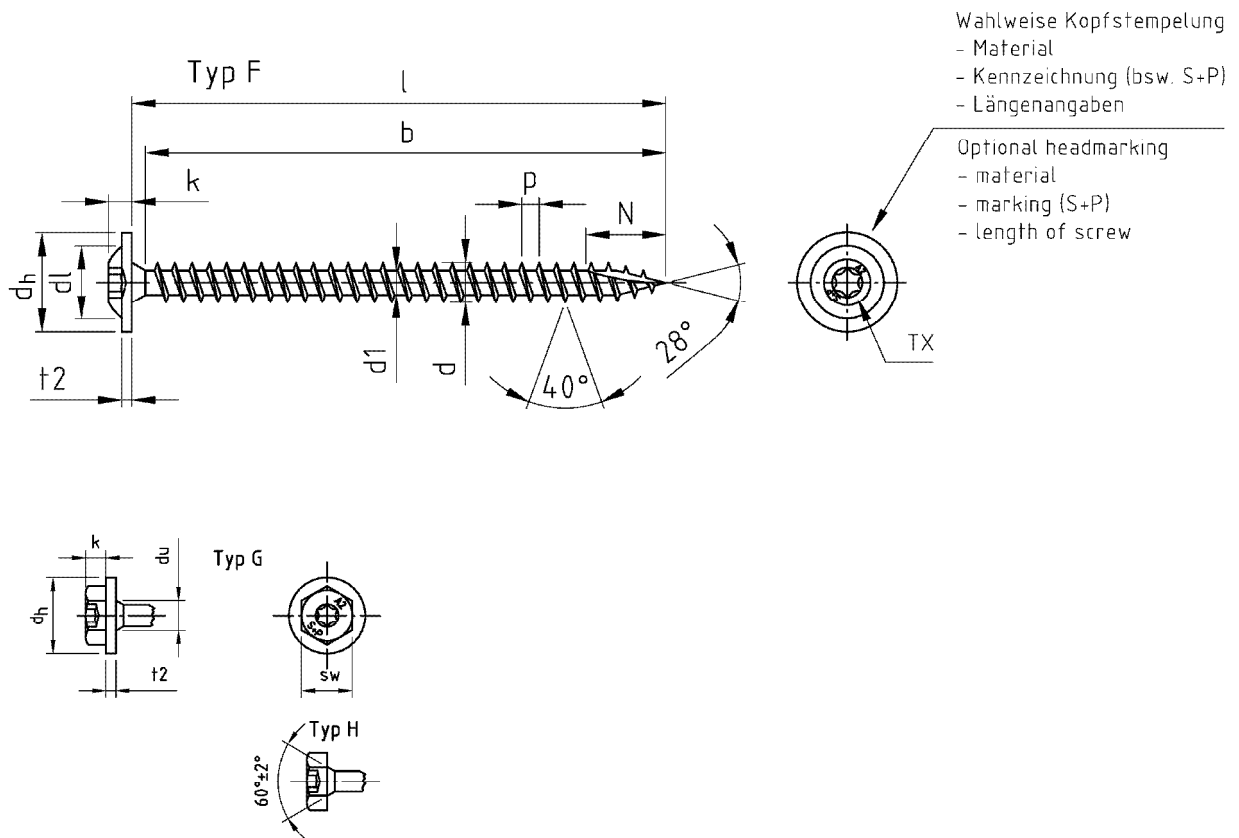

Bezeichnung	SP-HBS/ Tellerkopf-Holzbauschrauben mit Schneldkerbe, Vollgewinde									
Description	SP-HBS/ Pan washer head timber screws with cutting point, full thread									
Nennmaß/ Nominal dia.	d	d1	dh	dl	k	p	t2	TX	sw	N
ø 3,0	3,0 -0,15	2,0 -0,15	9,0 ±1,0	4,5	2,2 ±0,4	1,35 ±10%	1,3 -0,5	10	3	5,5 ±0,5
ø 3,2	3,2 -0,15	2,1 -0,15	10,0 ±1,0	5,0	2,5 ±0,4	1,45 ±10%	1,4 -0,5	10	4	6,5 ±0,5
ø 3,5	3,5 -0,3	2,4 -0,3	11,0 ±1,0	6,0	2,7 ±0,4	1,6 ±10%	1,5 -0,5	10/15	5	7,0 ±0,5
ø 4,0	4,0 -0,3	2,6 -0,3	12,0 ±1,0	7,0	3,0 ±0,4	1,8 ±10%	1,5 -0,5	15/20	6	7,5 ±0,5
ø 4,5	4,5 -0,3	2,8 -0,3	13,0 ±1,0	8,0	3,2 ±0,4	2,0 ±10%	1,5 -0,5	20/25	7	8,5 ±0,5
ø 5,0	5,0 -0,3	3,0 -0,3	14,0 ±1,0	9,0	3,5 ±0,4	2,2 ±10%	1,5 -0,5	20/25	8	9,5 ±0,5
ø 6,0	6,0 -0,3	3,7 -0,3	15,0 ±1,0	11,0	3,8 ±0,4	2,6 ±10%	2,0 -0,5	25/30	10	11,0 ±1

Nennmaß/ Nominal dia.	ø 3,0	ø 3,2	ø 3,5	ø 4,0	ø 4,5	ø 5,0	ø 6,0
l min. ±1	18	19	19	23	23	28	36
l max. ±1	45	40	50	80	100	100	110
b ±1	min. /+ k	16	16	16	20	25	30
	max. /+ k	40	36	45	75	90	100

Andere Schraubenlängen im Bereich  $L_{min} \leq L \leq L_{max}$  sind zulässig / Others screws lengths with  $L_{min} \leq L \leq max$  are allowed

S+P screws

SP-HBS  
Pan washer head timber screw, fully threaded

Annex 4.12

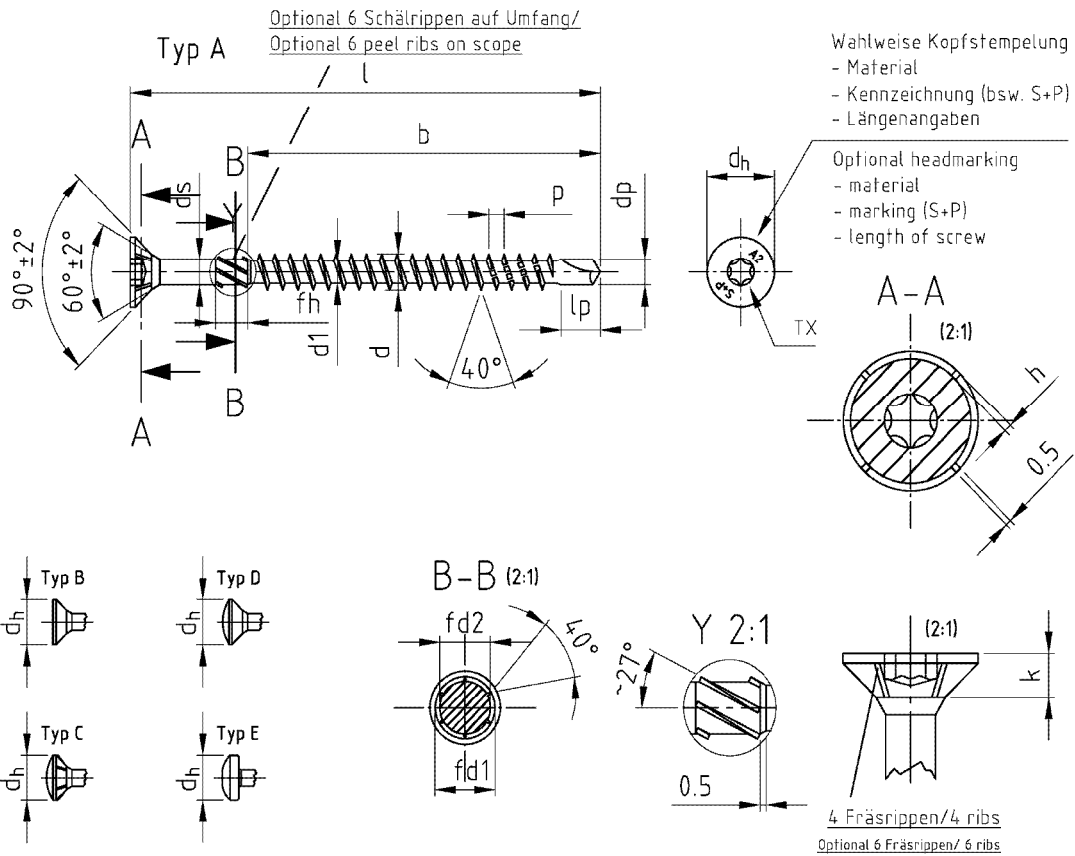

Mit fließendem Übergang vom Gewinde zum Schaft/ with floating crossing between shank and thread

Bezeichnung	SP-Drill/ Seko-Holzbauschrauben mit Bohrspitze												
Description	SP-Drill/ CSK head timber screws drilling-point												
Nennmaß/ Nominal dia.	d	d1	dp	dh	ds	k	p	lp	TX	h	fd1	fd2	
ø 3,0	3,0 -0,15	2,0 -0,15	2,3 -0,1	6,0 -0,4	2,15 ±0,05	1,9 -0,3	1,35 ±10%	3,0	10	0,3	2,80 -0,15	1,75 -0,15	
ø 3,2	3,2 -0,15	2,1 -0,15	2,4 -0,4	6,5 -0,4	2,3 ±0,05	2,0 -0,3	1,45 ±10%	3,1	10	0,3	3,15 -0,15	1,85 -0,15	
ø 3,5	3,5 -0,3	2,4 -0,3	2,8 -0,5	7,0 -0,4	2,5 ±0,05	2,1 -0,3	1,6 ±10%	3,5	10/15	0,3	3,45 -0,25	2,4 -0,15	
ø 4,0	4,0 -0,3	2,6 -0,3	3,0 -0,5	8,0 -0,5	2,84 ±0,05	2,5 -0,4	1,8 ±10%	3,7	15/20	0,5	3,70 -0,25	2,7 -0,15	
ø 4,5	4,5 -0,3	2,8 -0,3	3,3 -0,5	9,0 -0,5	3,11 ±0,05	2,7 -0,4	2,0 ±10%	4,7	20/25	0,5	3,95 -0,25	2,9 -0,15	
ø 5,0	5,0 -0,3	3,0 -0,3	3,6 -0,5	10,0 -0,5	3,54 ±0,05	3,0 -0,5	2,2 ±10%	5,2	20/25	0,5	4,2 -0,3	3,5 -0,15	
ø 6,0	6,0 -0,3	3,7 -0,3	4,4 -0,6	12,0 -0,5	4,25 ±0,05	3,6 -0,5	2,6 ±10%	5,8	25/30	0,5	5,1 -0,3	4,3 -0,25	

l -1/2 IT17	30	35	40	45	50	55	60	65	70	75	80	90	100	120-200	
ø 3,0 b ±1	18	24	24	30	30	-	-	-	-	-	-	-	-	-	
ø 3,2 b ±1	18	24	24	30	30	36	36	-	-	-	-	-	-	-	
ø 3,5 b ±1	18	24	24	30	30	36	36	-	-	-	-	-	-	-	
ø 4,0 b ±1	18	24	24	30	30	36	36	42	42	48	54	54	60	70	
ø 4,5 b ±1	18	24	24	30	30	36	36	42	42	48	54	54	60	70	
ø 5,0 b ±1	-	24	24	30	30	36	36	42	42	48	54	54	60	70	
ø 6,0 b ±1	-	24	24	30	30	36	36	42	42	48	54	54	60	70	
fh	4,0 -0,2			6,0 -0,2						12,0 -0,6					

S+P screws

SP-Drill  
CSK head timber screw with drilling point

Annex 4.13

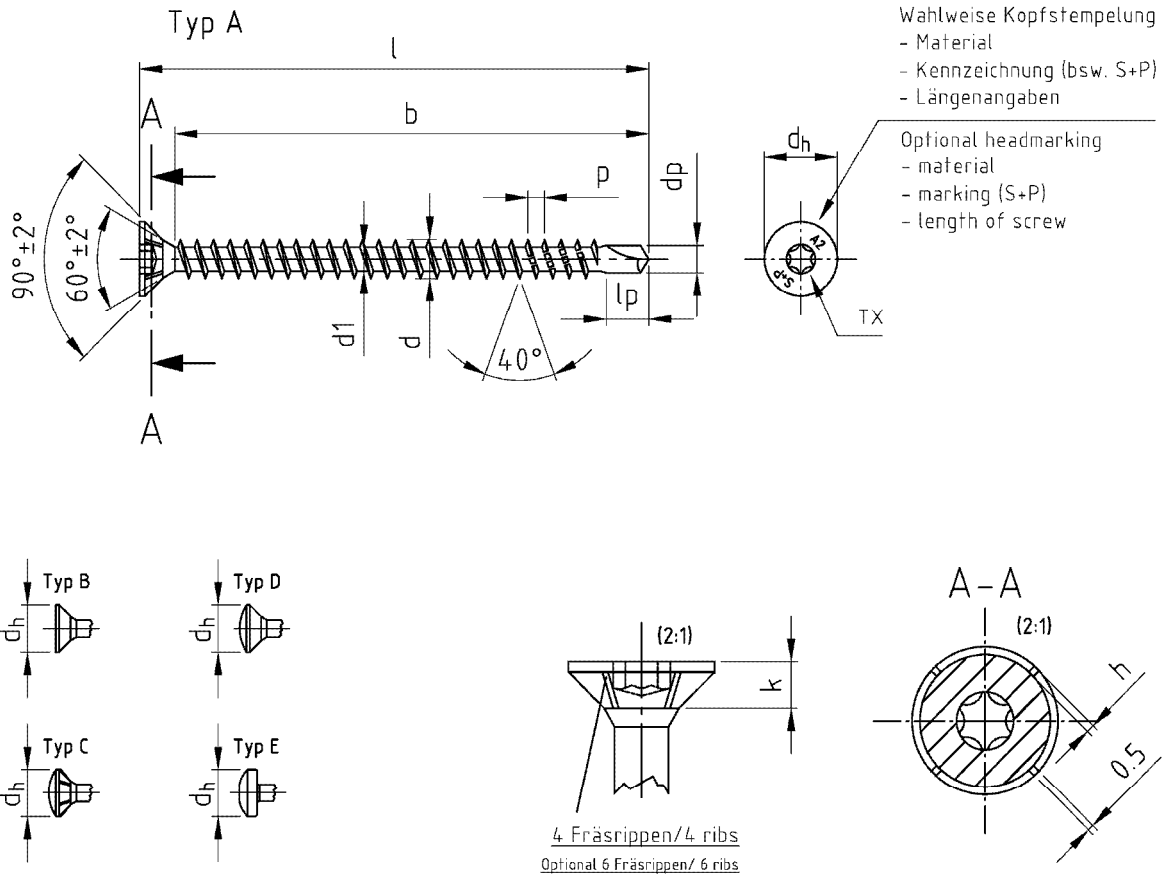

Bezeichnung	SP-Drill/ Seko-Holzbauschrauben mit Bohrspitze, Vollgewinde								
Description	SP-Drill/ CSK head timber screws drilling-point, full thread								
Nennmaß/ Nominal dia.	d	d1	dp	dh	k	p	lp	TX	h
∅ 3,0	3,0 -0,15	2,0 -0,15	2,3 -0,1	6,0 -0,4	1,9 -0,3	1,35 ±10%	3,0	10	0,3
∅ 3,2	3,2 -0,15	2,1 -0,15	2,4 -0,4	6,5 -0,4	2,0 -0,3	1,45 ±10%	3,1	10	0,3
∅ 3,5	3,5 -0,3	2,4 -0,3	2,8 -0,5	7,0 -0,4	2,1 -0,3	1,6 ±10%	3,5	10/15	0,3
∅ 4,0	4,0 -0,3	2,6 -0,3	3,0 -0,5	8,0 -0,5	2,5 -0,4	1,8 ±10%	3,7	15/20	0,5
∅ 4,5	4,5 -0,3	2,8 -0,3	3,3 -0,5	9,0 -0,5	2,7 -0,4	2,0 ±10%	4,7	20/25	0,5
∅ 5,0	5,0 -0,3	3,0 -0,3	3,6 -0,5	10,0 -0,5	3,0 -0,5	2,2 ±10%	5,2	20/25	0,5
∅ 6,0	6,0 -0,3	3,7 -0,3	4,4 -0,6	12,0 -0,5	3,6 -0,5	2,6 ±10%	5,8	25/30	0,5

Nennmaß/ Nominal dia.	∅ 3,0	∅ 3,2	∅ 3,5	∅ 4,0	∅ 4,5	∅ 5,0	∅ 6,0
l min. ±1	18	19	19	23	23	28	36
l max. ±1	45	40	50	80	100	100	110
b ±1	min. /+ k	16	16	16	20	25	30
	max. /+ k	40	36	45	75	90	100

Andere Schraubenlängen im Bereich  $L_{min} \leq L \leq L_{max}$  sind zulässig / Others screws lengths with  $L_{min} \leq L \leq L_{max}$  are allowed

S+P screws

SP-Drill  
CSK head timber screw with drilling point, fully threaded

Annex 4.14

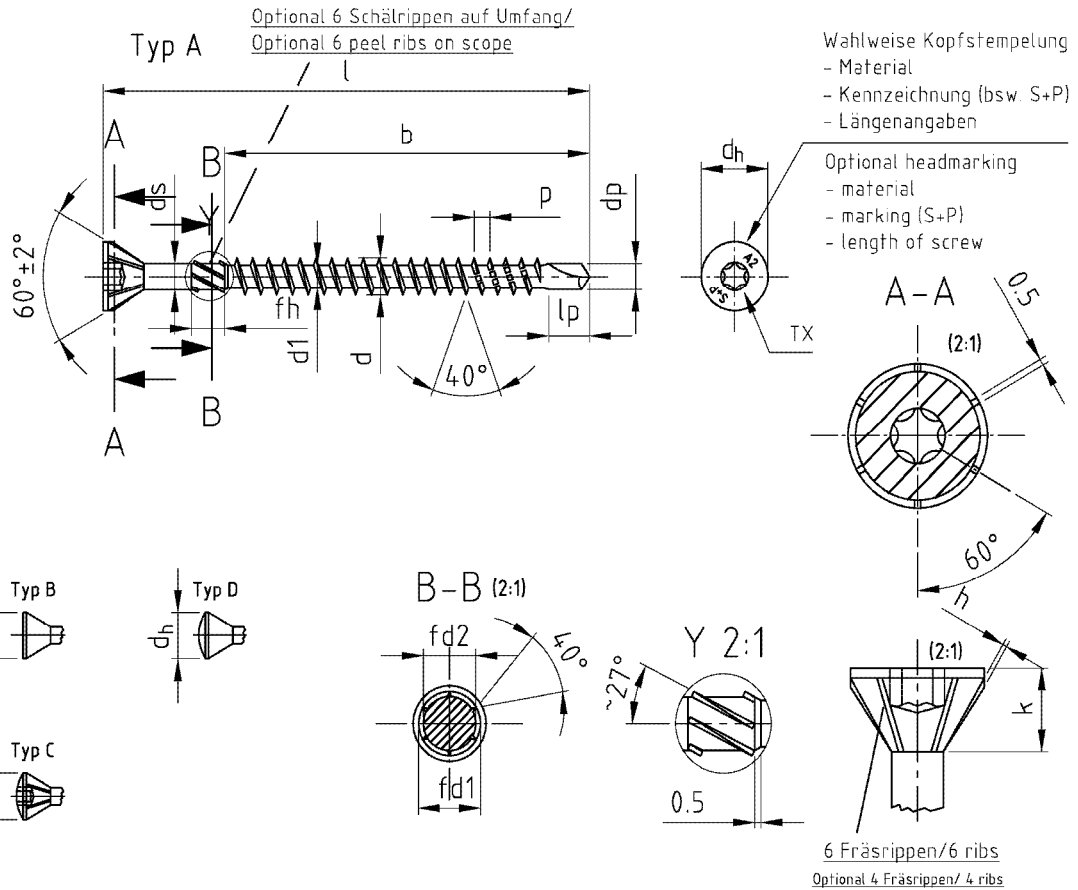

Mit fließendem Übergang vom Gewinde zum Schaft/ with floating crossing between shank and thread

Bezeichnung	SP-Drill-60°/ Seko-Holzbauschrauben mit Bohrspitze, 60° Kopf											
Description	SP-Drill-60°/ CSK head timber screws drilling-point, 60° Kopf											
Nennmaß/ Nominal dia.	d	d1	dp	dh	ds	k	p	lp	TX	h	fd1	fd2
Ø 3,0	3,0 -0,15	2,0 -0,15	2,3 -0,1	4,5 ±0,5	2,15 ±0,05	1,8 ±0,5	1,35 ±10%	3,0	10	0,3	2,90 -0,15	1,75 -0,15
Ø 3,2	3,2 -0,15	2,1 -0,15	2,4 -0,4	5,0 ±0,5	2,3 ±0,05	2,0 ±0,5	1,45 ±10%	3,1	10	0,3	3,15 -0,15	1,85 -0,15
Ø 3,5	3,5 -0,3	2,4 -0,3	2,8 -0,5	5,5 ±0,5	2,5 ±0,05	2,2 ±0,5	1,6 ±10%	3,5	10	0,3	3,45 -0,25	2,4 -0,15
Ø 4,0	4,0 -0,3	2,6 -0,3	3,0 -0,5	6,0 ±0,5	2,84 ±0,05	2,75 ±0,5	1,8 ±10%	3,7	15/20	0,5	3,70 -0,25	2,7 -0,15
Ø 4,5	4,5 -0,3	2,8 -0,3	3,3 -0,5	7,0 ±0,5	3,11 ±0,05	3,35 ±0,5	2,0 ±10%	4,7	20/25	0,5	3,95 -0,25	2,9 -0,15
Ø 5,0	5,0 -0,3	3,0 -0,3	3,6 -0,5	7,5 ±0,5	3,54 ±0,05	3,45 ±0,5	2,2 ±10%	5,2	20/25	0,5	4,2 -0,3	3,5 -0,15
Ø 6,0	6,0 -0,3	3,7 -0,3	4,4 -0,6	11,0 ±0,5	4,25 ±0,05	5,85 ±0,5	2,6 ±10%	5,8	25/30	0,5	5,1 -0,3	4,3 -0,25

l -1/2 IT17	30	35	40	45	50	55	60	65	70	75	80	90	100	120-200	
Ø 3,0 b ±1	18	24	24	30	30	-	-	-	-	-	-	-	-	-	
Ø 3,2 b ±1	18	24	24	30	30	36	36	-	-	-	-	-	-	-	
Ø 3,5 b ±1	18	24	24	30	30	36	36	-	-	-	-	-	-	-	
Ø 4,0 b ±1	18	24	24	30	30	36	36	42	42	48	54	-	-	-	
Ø 4,5 b ±1	18	24	24	30	30	36	36	42	42	48	54	54	60	70	
Ø 5,0 b ±1	-	24	24	30	30	36	36	42	42	48	54	54	60	70	
Ø 6,0 b ±1	-	24	24	30	30	36	36	42	42	48	54	54	60	70	
fh	4,0 -0,2			6,0 -0,2						12,0 -0,6					

S+P screws

SP-Drill-60°  
CSK head timber screw with drilling point, 60° head

Annex 4.15

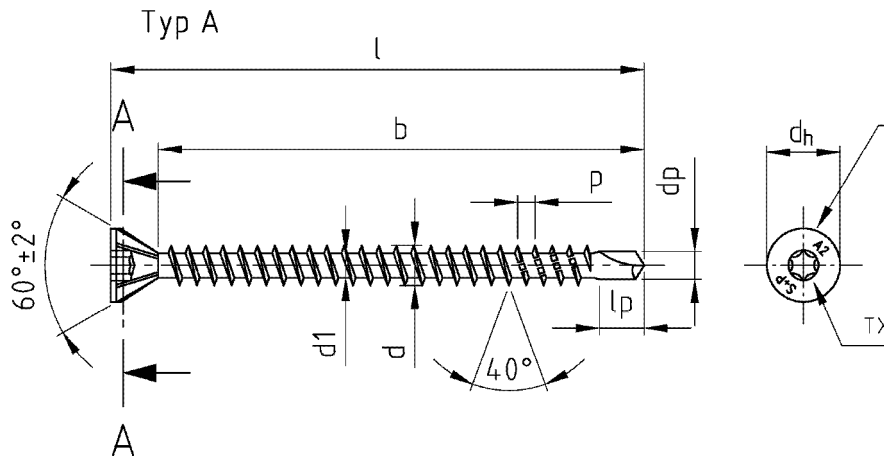

Wahlweise Kopfstempelung  
- Material  
- Kennzeichnung (bsw. S+P)  
- Längenangaben

Optional headmarking  
- material  
- marking (S+P)  
- length of screw

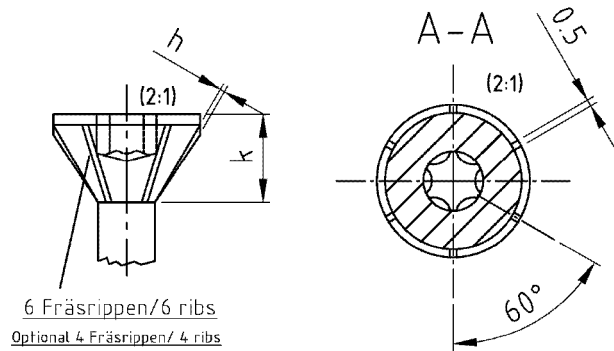
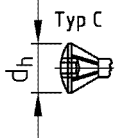
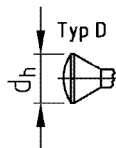
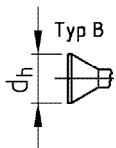

6 Fräsrippen/6 ribs  
Optional 4 Fräsrippen/ 4 ribs

Bezeichnung	SP-Drill-60°/ Seko-Holzbauschrauben mit Bohrspitze, 60° Kopf, Vollgewinde									
Description	SP-Drill-60°/ CSK head timber screws drilling-point, 60° Kopf, full thread									
Nennmaß/ Nominal dia.	d	d1	dp	dh	k	p	lp	TX	h	
∅ 3,0	3,0 -0,15	2,0 -0,15	2,3 -0,1	4,5 ±0,5	1,8 ±0,5	1,35 ±10%	3,0	10	0,3	
∅ 3,2	3,2 -0,15	2,1 -0,15	2,4 -0,4	5,0 ±0,5	2,0 ±0,5	1,45 ±10%	3,1	10	0,3	
∅ 3,5	3,5 -0,3	2,4 -0,3	2,8 -0,5	5,5 ±0,5	2,2 ±0,5	1,6 ±10%	3,5	10	0,3	
∅ 4,0	4,0 -0,3	2,6 -0,3	3,0 -0,5	6,0 ±0,5	2,75 ±0,5	1,8 ±10%	3,7	15/20	0,5	
∅ 4,5	4,5 -0,3	2,8 -0,3	3,3 -0,5	7,0 ±0,5	3,35 ±0,5	2,0 ±10%	4,7	20/25	0,5	
∅ 5,0	5,0 -0,3	3,0 -0,3	3,6 -0,5	7,5 ±0,5	3,45 ±0,5	2,2 ±10%	5,2	20/25	0,5	
∅ 6,0	6,0 -0,3	3,7 -0,3	4,4 -0,6	11,0 ±0,5	5,85 ±0,5	2,6 ±10%	5,8	25/30	0,5	

Nennmaß/ Nominal dia.	∅ 3,0	∅ 3,2	∅ 3,5	∅ 4,0	∅ 4,5	∅ 5,0	∅ 6,0
l min. ±1	18	19	19	23	23	28	36
l max. ±1	45	40	50	80	100	100	110
b ±1	min. /+ k	16	16	16	20	25	30
	max. /+ k	40	36	45	75	90	100

Andere Schraubenlängen im Bereich  $L_{min} \leq L \leq L_{max}$  sind zulässig / Others screws lengths with  $L_{min} \leq L \leq L_{max}$  are allowed

S+P screws

SP-Drill-60°  
CSK head timber screw, 60° head with drilling point, fully threaded

Annex 4.16

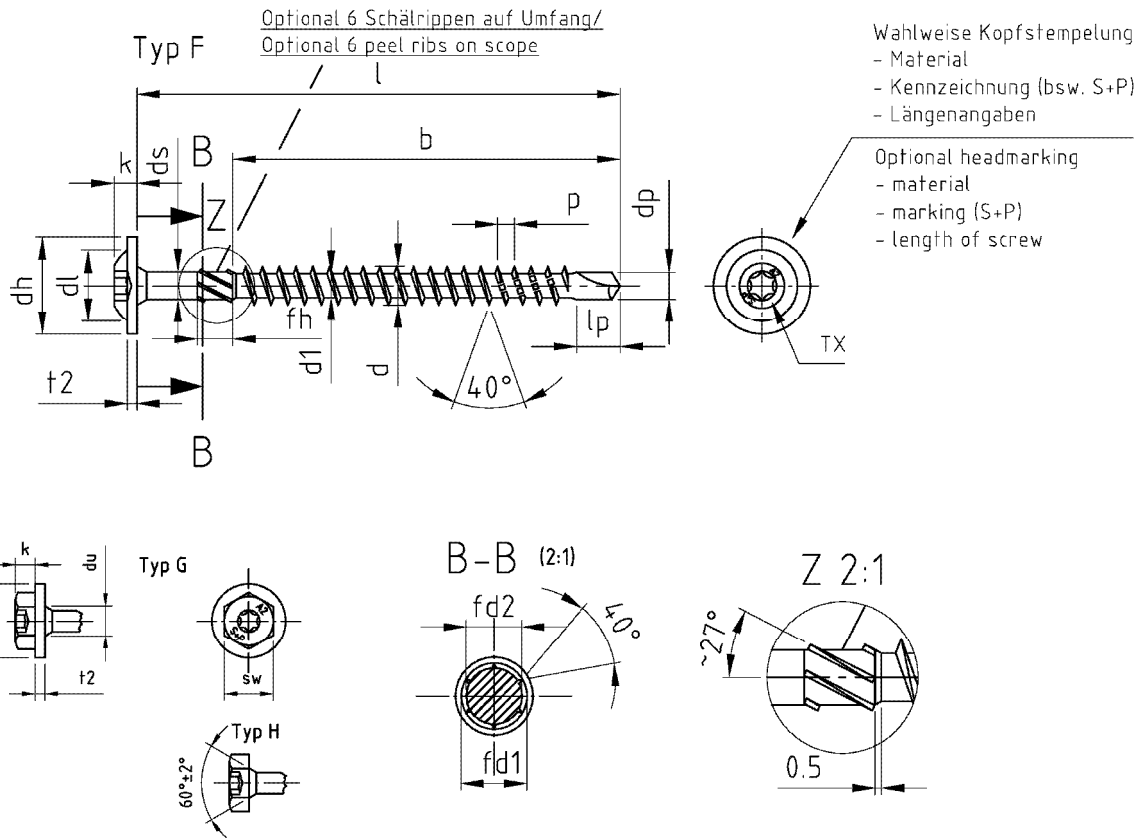

Mit fließendem Übergang vom Gewinde zum Schaft/ with floating crossing between shank and thread

Bezeichnung	SP-Drill/ Tellerkopf-Holzbauschrauben mit Teilgewinde und Bohrspitze														
Description	SP-Drill/ Pan washer head timber screws with partial thread and drilling point														
Nennmaß/ Nominal dia.	d	d1	dp	dh	ds	dl	k	p	t2	lp	TX	sw	fd1	fd2	
ø 3,0	3,0 -0,15	2,0 -0,15	2,3 -0,1	9,0 ±1,0	2,15 ±0,05	4,5	2,2 ±0,4	1,35 ±10%	1,3 -0,5	3,0	10	3	2,90 -0,15	1,75 -0,15	
ø 3,2	3,2 -0,15	2,1 -0,15	2,4 -0,4	10,0 ±1,0	2,3 ±0,05	5,0	2,5 ±0,4	1,45 ±10%	1,4 -0,5	3,1	10	4	3,15 -0,15	1,85 -0,15	
ø 3,5	3,5 -0,3	2,4 -0,3	2,8 -0,5	11,0 ±1,0	2,5 ±0,05	6,0	2,7 ±0,4	1,8 ±10%	1,5 -0,5	3,5	10/15	5	3,45 -0,25	2,4 -0,15	
ø 4,0	4,0 -0,3	2,6 -0,3	3,0 -0,5	12,0 ±1,0	2,84 ±0,05	7,0	3,0 ±0,4	1,8 ±10%	1,5 -0,5	3,7	15/20	6	3,70 -0,25	2,7 -0,15	
ø 4,5	4,5 -0,3	2,8 -0,3	3,3 -0,5	13,0 ±1,0	3,11 ±0,05	8,0	3,2 ±0,4	2,0 ±10%	1,5 -0,5	4,7	20/25	7	3,95 -0,25	2,9 -0,15	
ø 5,0	5,0 -0,3	3,0 -0,3	3,6 -0,5	14,0 ±1,0	3,54 ±0,05	9,0	3,5 ±0,4	2,2 ±10%	1,5 -0,5	5,2	20/25	8	4,2 -0,3	3,5 -0,15	
ø 6,0	6,0 -0,3	3,7 -0,3	4,4 -0,6	15,0 ±1,0	4,25 ±0,05	11,0	3,8 ±0,4	2,6 ±10%	2,0 -0,5	5,8	25/30	10	5,1 -0,3	4,3 -0,25	

l -1/2 IT17	30	35	40	45	50	55	60	65	70	75	80	90	100	120-200
ø 3,0 b ±1	18	24	24	30	30	-	-	-	-	-	-	-	-	-
ø 3,2 b ±1	18	24	24	30	30	36	36	-	-	-	-	-	-	-
ø 3,5 b ±1	18	24	24	30	30	36	36	-	-	-	-	-	-	-
ø 4,0 b ±1	18	24	24	30	30	36	36	42	42	48	54	54	60	70
ø 4,5 b ±1	18	24	24	30	30	36	36	42	42	48	54	54	60	70
ø 5,0 b ±1	-	24	24	30	30	36	36	42	42	48	54	54	60	70
ø 6,0 b ±1	-	24	24	30	30	36	36	42	42	48	54	54	60	70
fh	4,0 -0,2				6,0 -0,2				12,0 -0,6					

S+P screws

SP-Drill  
Pan washer head timber screw with drilling point

Annex 4.17

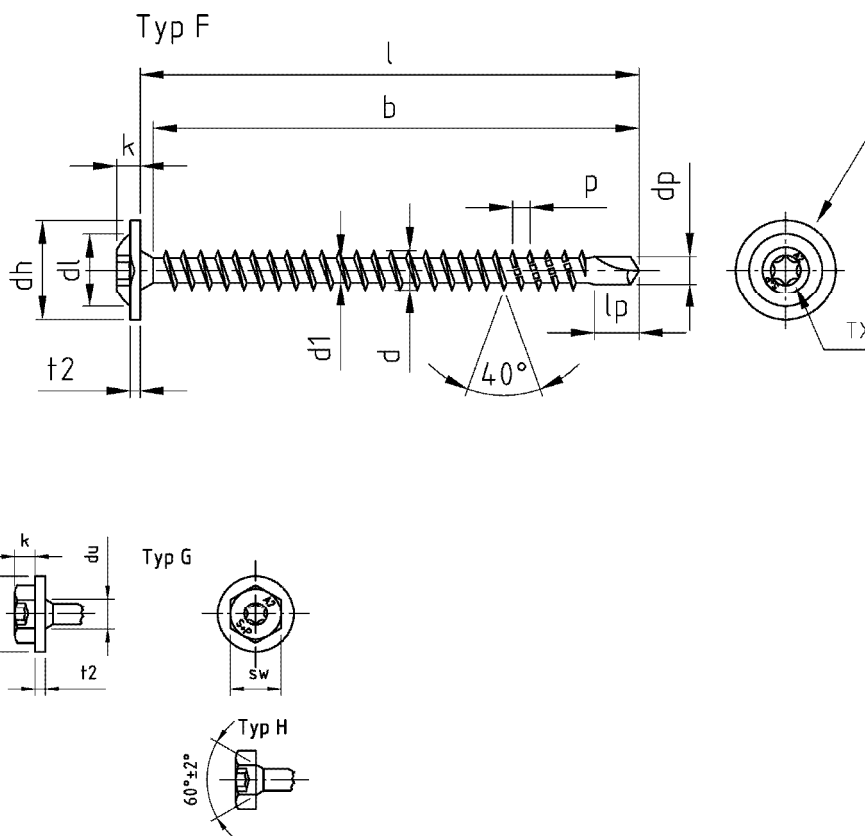

Wahlweise Kopfstempelung  
- Material  
- Kennzeichnung (bsw. S+P)  
- Längenangaben

Optional headmarking  
- material  
- marking (S+P)  
- length of screw

Bezeichnung	SP-Drill/ Tellerkopf-Holzbauschrauben Bohrspitze, Vollgewinde										
Description	SP-Drill/ Pan washer head timber screws with drilling point, full thread										
Nennmaß/ Nominal dia.	d	d1	dp	dh	dl	k	p	t2	lp	TX	sw
∅ 3,0	3,0 -0,15	2,0 -0,15	2,3 -0,1	9,0 ±1,0	4,5	2,2 ±0,4	1,35 ±10%	1,3 -0,5	3,0	10	3
∅ 3,2	3,2 -0,15	2,1 -0,15	2,4 -0,4	10,0 ±1,0	5,0	2,5 ±0,4	1,45 ±10%	1,4 -0,5	3,1	10	4
∅ 3,5	3,5 -0,3	2,4 -0,3	2,8 -0,5	11,0 ±1,0	6,0	2,7 ±0,4	1,6 ±10%	1,5 -0,5	3,5	10/15	5
∅ 4,0	4,0 -0,3	2,6 -0,3	3,0 -0,5	12,0 ±1,0	7,0	3,0 ±0,4	1,8 ±10%	1,5 -0,5	3,7	15/20	6
∅ 4,5	4,5 -0,3	2,8 -0,3	3,3 -0,5	13,0 ±1,0	8,0	3,2 ±0,4	2,0 ±10%	1,5 -0,5	4,7	20/25	7
∅ 5,0	5,0 -0,3	3,0 -0,3	3,6 -0,5	14,0 ±1,0	9,0	3,5 ±0,4	2,2 ±10%	1,5 -0,5	5,2	20/25	8
∅ 6,0	6,0 -0,3	3,7 -0,3	4,4 -0,6	15,0 ±1,0	11,0	3,8 ±0,4	2,6 ±10%	2,0 -0,5	5,8	25/30	10

Nennmaß/ Nominal dia.	∅ 3,0	∅ 3,2	∅ 3,5	∅ 4,0	∅ 4,5	∅ 5,0	∅ 6,0
l min. ±1	18	19	19	23	23	28	36
l max. ±1	45	40	50	80	100	100	110
b ±1	min. /+ k	16	16	16	20	25	30
	max. /+ k	40	36	45	75	90	100

Andere Schraubenlängen im Bereich  $L_{min} \leq L \leq L_{max}$  sind zulässig / Others screws lengths with  $L_{min} \leq L \leq max$  are allowed

S+P screws

SP-Drill  
Pan washer head timber screw with drilling point, fully threaded

Annex 4.18



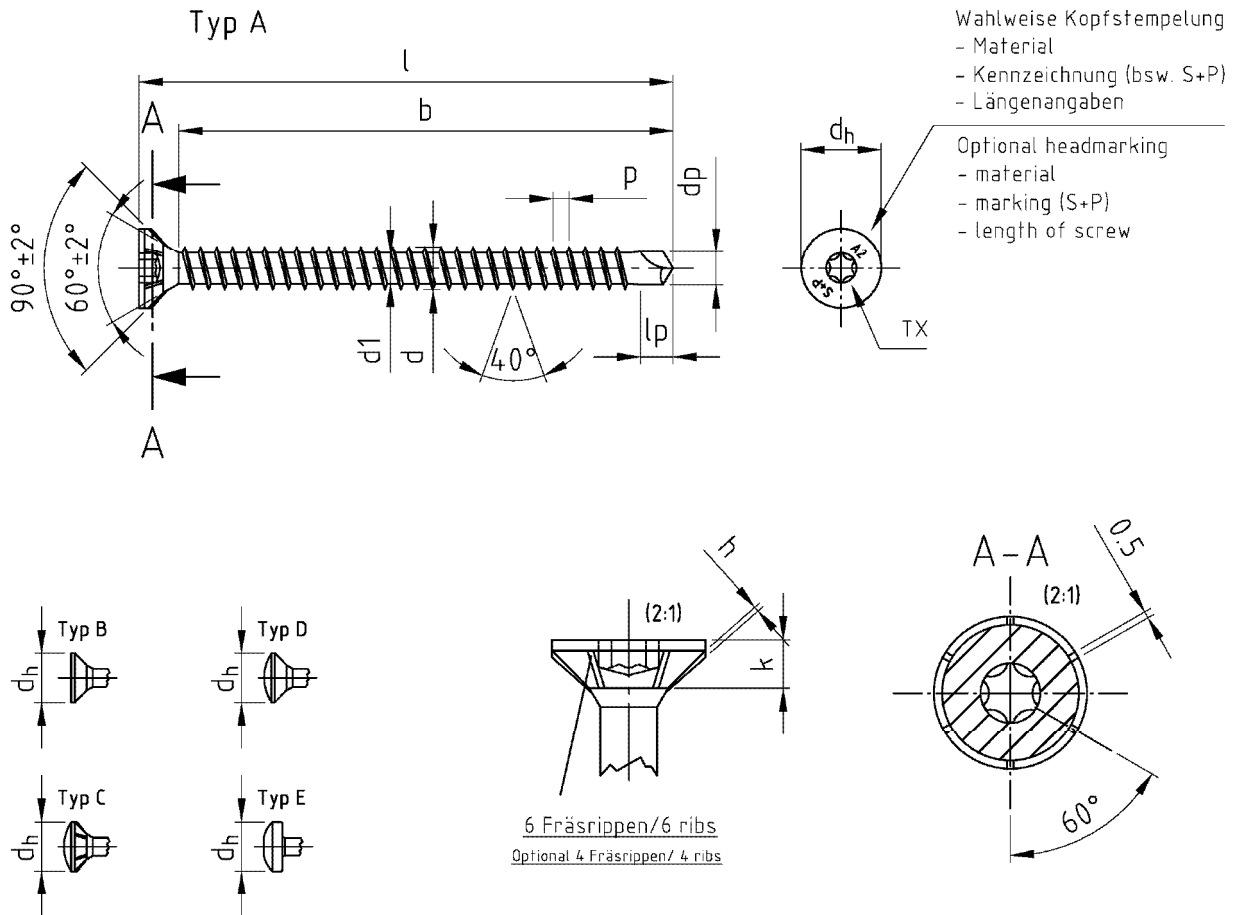

Bezeichnung	SP-Super-Drill/ Seko-Holzbauschrauben mit Bohrspitze, Vollgewinde								
Description	SP-Super-Drill/ CSK head wood screws with drilling-point, full thread								
Nennmaß/ Nominal dia.	d	d1	dp	dh	k	p	lp	TX	h
ø 4,0	4,1 +0,2/-0,1	3,0 ±0,1	3,0 ±0,15	8,0 -0,5	2,5 -0,4	1,8 ±10%	3,5 ±0,2	15/20	0,35 ±0,1
ø 4,5	4,6 +0,2/-0,1	3,3 ±0,1	3,4 ±0,15	9,0 -0,5	2,7 -0,4	2,0 ±10%	3,7 ±0,2	20/25	0,40 ±0,1
ø 5,0	5,3 +0,2/-0,1	3,7 ±0,1	4,0 ±0,15	10,0 -0,5	3,0 -0,5	2,2 ±10%	4,5 ±0,2	20/25	0,45 ±0,1
ø 6,0	6,5 +0,2/-0,1	4,7 ±0,1	5,0 ±0,15	12,0 -0,5	3,6 -0,5	2,4 ±10%	4,9 ±0,2	25/30	0,50 ±0,1

Nennmaß/ Nominal dia.	ø 4,0	ø 4,5	ø 5,0	ø 6,0
l min. ±1	23	23	28	36
l max. ±1	80	100	100	110
b ±1	min. /+ k	20	25	30
	max. /+ k	75	90	100
Andere Schraubenlängen im Bereich $L_{min} \leq L \leq L_{max}$ sind zulässig / Others screws lengths with $L_{min} \leq L \leq L_{max}$ are allowed				

S+P screws

SP-Super-Drill  
CSK head timber screw with drilling point, fully threaded

Annex 4.20

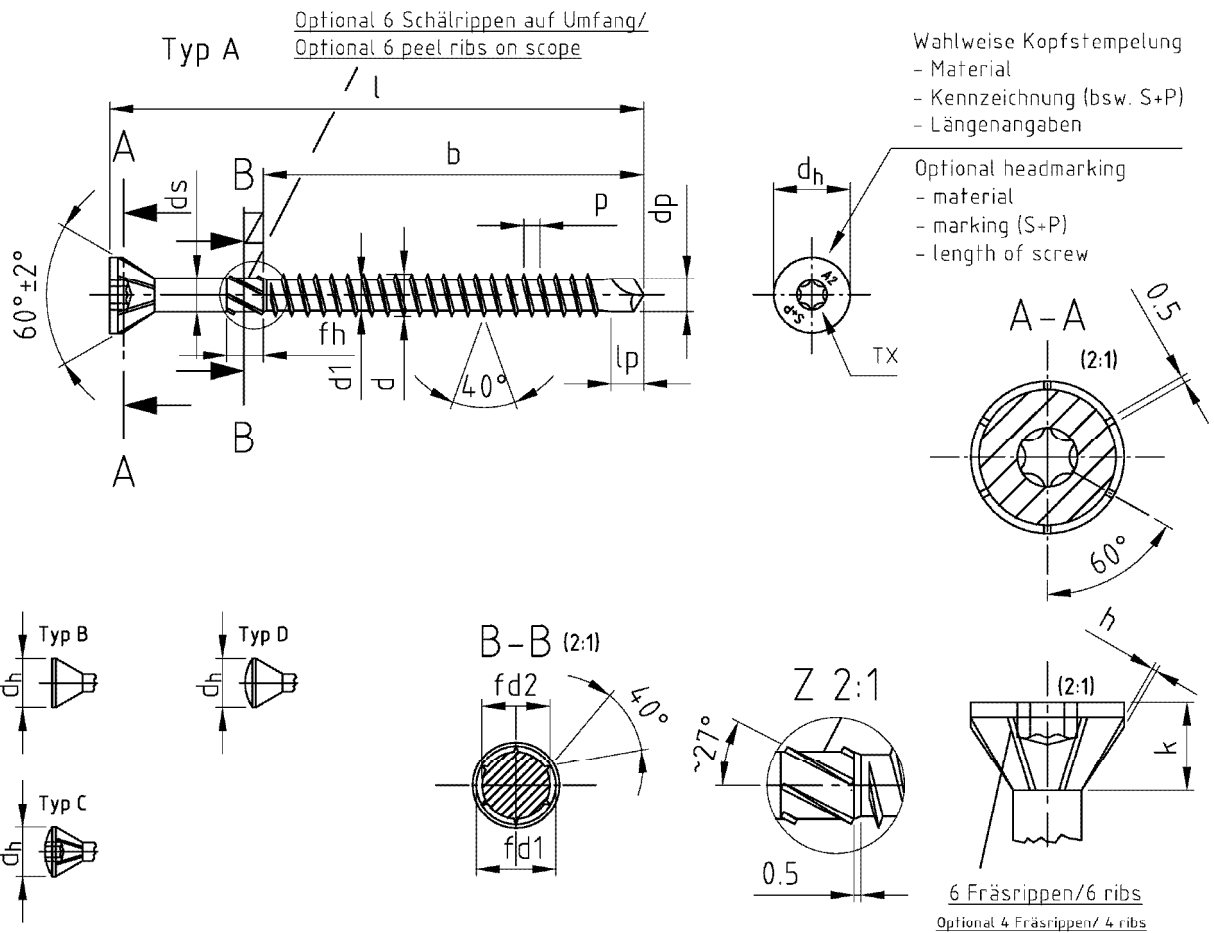

Mit fließendem Übergang vom Gewinde zum Schaft/ with floating crossing between shank and thread

Bezeichnung	SP-Super-Drill 60°/ Seko-Holzbauschrauben mit Bohrspitze, 60° kopf											
Description	SP-Super-Drill 60°/ CSK head wood screws with drilling-point, 60° head											
Nennmaß/ Nominal dia.	d	d1	dp	dh	ds	k	p	lp	TX	h	fd1	fd2
ø 4,0	4,1 +0,2/-0,1	3,0 ±0,1	3,0 ±0,15	7,0 -0,5	3,2 ±0,05	3,3 ±0,5	1,8 ±10%	3,5 ±0,2	15/20	0,35 ±0,1	4,06 -0,25	3,2 -0,15
ø 4,5	4,6 +0,2/-0,1	3,3 ±0,1	3,4 ±0,15	8,0 -0,5	3,5 ±0,05	3,9 ±0,5	2,0 ±10%	3,7 ±0,2	20/25	0,40 ±0,1	4,36 -0,3	3,5 -0,15
ø 5,0	5,3 +0,2/-0,1	3,7 ±0,1	4,0 ±0,15	8,5 -0,5	4,1 ±0,05	4,0 ±0,5	2,2 ±10%	4,5 ±0,2	20/25	0,45 ±0,1	5,06 -0,3	4,1 -0,25
ø 6,0	6,5 +0,2/-0,1	4,7 ±0,1	5,0 ±0,15	11,0 -0,5	5,1 ±0,05	5,1 ±0,5	2,4 ±10%	4,9 ±0,2	25/30	0,50 ±0,1	5,96 -0,3	5,1 -0,25

l -1/2 IT17	30	35	40	45	50	60	70	80	90	100	120-200	
ø 4,0 b ±1	21	26	26	28	33	40	50	50	-	-	-	
ø 4,5 b ±1	-	26	26	31	33	40	50	50	58	58	-	
ø 5,0 b ±1	-	-	26	30	36	40	50	50	58	58	66	
ø 6,0 b ±1	-	-	-	-	30	35	47	57	57	66	66	
fh	4,0 -0,2			6,0 -0,2			12,0 -0,6					

S+P screws

SP-Super-Drill 60°  
CSK head timber screw with drilling point, 60° head

Annex 4.21

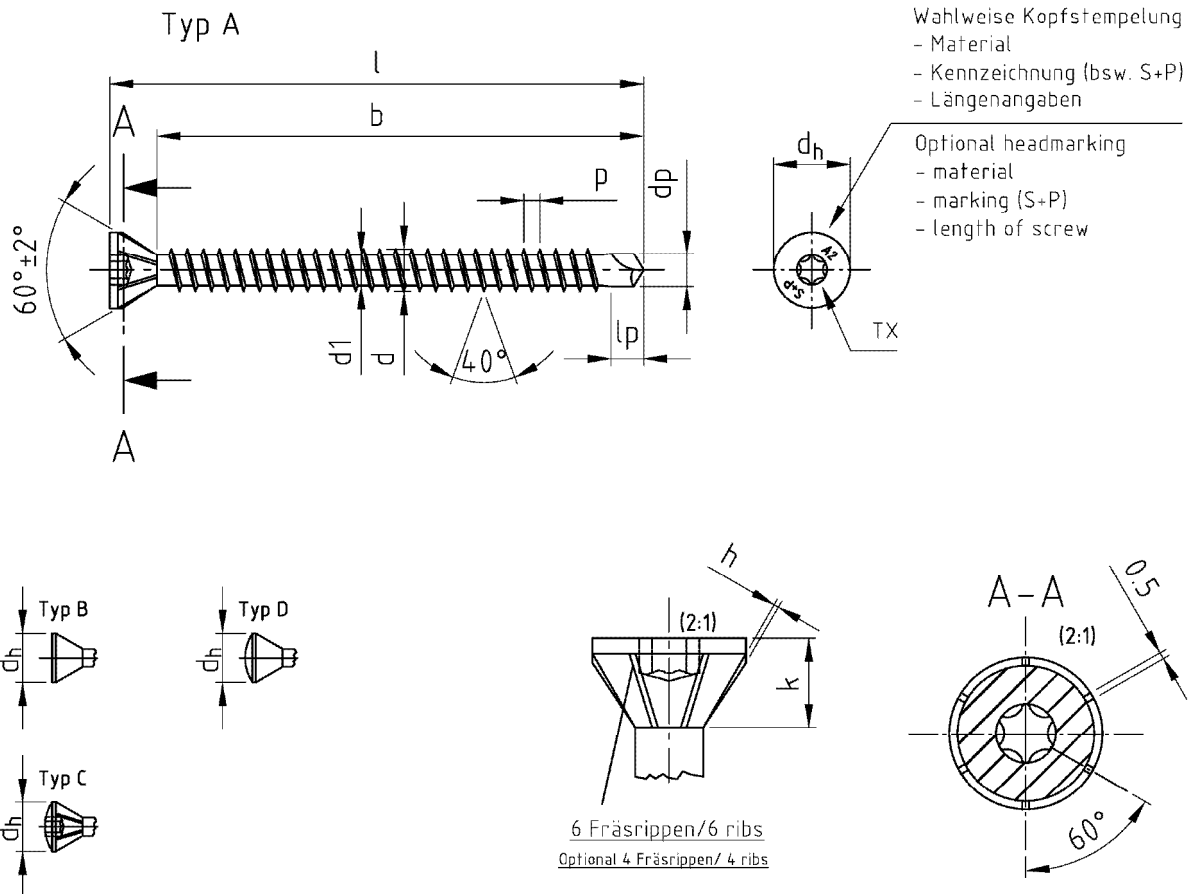

Bezeichnung	SP-Super-Drill 60°/ Seko-Holzbauschrauben mit Bohrspitze, 60° kopf, Vollgewinde								
Description	SP-Super-Drill 60°/ CSK head wood screws with drilling-point, 60° head, full thread								
Nennmaß/ Nominal dia.	d	d1	dp	dh	k	p	lp	TX	h
ø 4,0	4,1 +0,2/-0,1	3,0 ±0,1	3,0 ±0,15	7,0 -0,5	3,3 ±0,5	1,8 ±10%	3,5 ±0,2	15/20	0,35 ±0,1
ø 4,5	4,6 +0,2/-0,1	3,3 ±0,1	3,4 ±0,15	8,0 -0,5	3,9 ±0,5	2,0 ±10%	3,7 ±0,2	20/25	0,40 ±0,1
ø 5,0	5,3 +0,2/-0,1	3,7 ±0,1	4,0 ±0,15	8,5 -0,5	4,0 ±0,5	2,2 ±10%	4,5 ±0,2	20/25	0,45 ±0,1
ø 6,0	6,5 +0,2/-0,1	4,7 ±0,1	5,0 ±0,15	11,0 -0,5	5,1 ±0,5	2,4 ±10%	4,9 ±0,2	25/30	0,50 ±0,1

Nennmaß/ Nominal dia.	ø 4,0	ø 4,5	ø 5,0	ø 6,0
l min. ±1	23	23	28	36
l max. ±1	80	100	100	110
b ±1	min. /+ k	20	25	30
	max. /+ k	75	90	100

Andere Schraubenlängen im Bereich  $L_{min} \leq L \leq L_{max}$  sind zulässig / Others screws lengths with  $L_{min} \leq L \leq L_{max}$  are allowed

S+P screws

SP-Super-Drill 60°  
CSK head timber screw with drilling point, 60° head, fully threaded

Annex 4.22

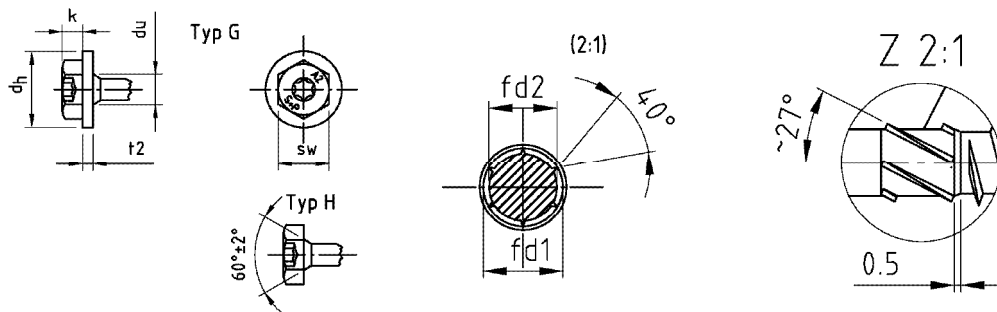
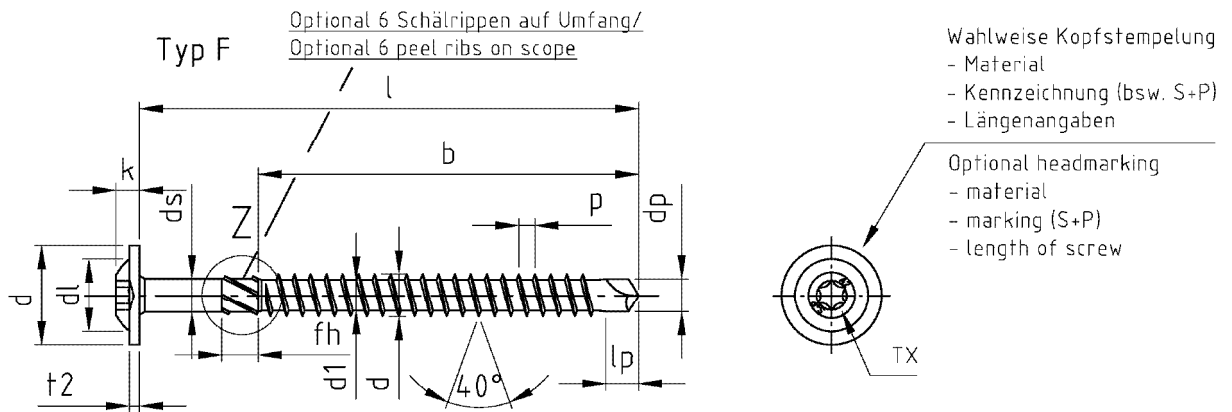

Mit fließendem Übergang vom Gewinde zum Schaft / with floating crossing between shank and thread

Bezeichnung	SP-Super-Drill/ Tellerkopf-Holzbohrschrauben mit Bohrspitze, Vollgewinde													
Description	SP-Super-Drill/ Pan washer head timber screws with drilling point, full thread													
Nennmaß/ Nominal dia.	d	d1	dp	dh	ds	dl	k	p	t2	lp	TX	sw	fd1	fd2
ø 4,0	4,1 +0,2/-0,1	3,0 ±0,1	3,0 ±0,15	12,0 ±1,0	3,2 ±0,05	7,0	3,0 ±0,4	1,8 ±10%	1,5 -0,5	3,5 ±0,2	15/20	6	4,06 -0,25	3,2 -0,15
ø 4,5	4,6 +0,2/-0,1	3,3 ±0,1	3,4 ±0,15	13,0 ±1,0	3,5 ±0,05	8,0	3,2 ±0,4	2,0 ±10%	1,5 -0,5	3,7 ±0,2	20/25	7	4,36 -0,3	3,5 -0,15
ø 5,0	5,3 +0,2/-0,1	3,7 ±0,1	4,0 ±0,15	14,0 ±1,0	4,1 ±0,05	9,0	3,5 ±0,4	2,2 ±10%	1,5 -0,5	4,5 ±0,2	20/25	8	5,06 -0,3	4,1 -0,25
ø 6,0	6,5 +0,2/-0,1	4,7 ±0,1	5,0 ±0,15	15,0 ±1,0	5,1 ±0,05	11,0	3,8 ±0,4	2,4 ±10%	2,0 -0,5	4,9 ±0,2	25/30	10	5,96 -0,3	5,1 -0,25

l -1/2 IT17	30	35	40	45	50	60	70	80	90	100	120	140-200
ø 4,0 b ±1	21	26	26	28	33	40	50	50	-	-	-	-
ø 4,5 b ±1	-	26	26	31	33	40	50	50	58	58	-	-
ø 5,0 b ±1	-	-	26	30	36	40	50	50	58	58	66	-
ø 6,0 b ±1	-	-	-	-	30	35	47	57	57	66	66	66
fh	4,0 -0,2			6,0 -0,2			12,0 -0,6					

S+P screws

SP-Super-Drill  
Pan washer head timber screw with drilling point

Annex 4.23

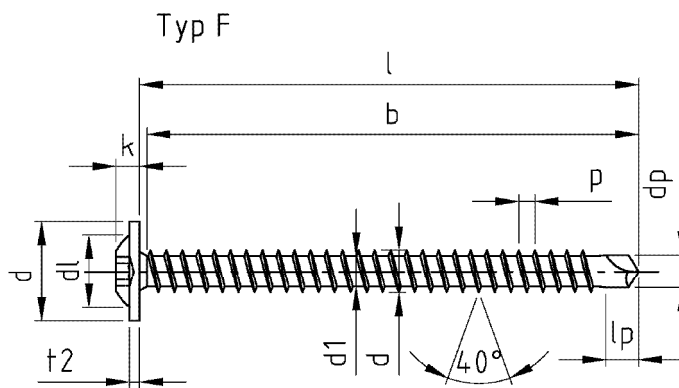

Wahlweise Kopfstempelung  
- Material  
- Kennzeichnung (bsw. S+P)  
- Längenangaben

Optional headmarking  
- material  
- marking (S+P)  
- length of screw

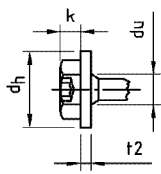

Typ G

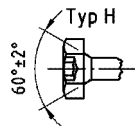
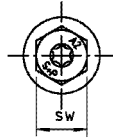

Bezeichnung	SP-Super-Drill/ Tellerkopf-Holzbauschrauben mit Bohrspitze, Vollgewinde										
Description	SP-Super-Drill/ Pan washer head timber screws with drilling point, full thread										
Nennmaß/ Nominal dia.	d	d1	dp	dh	dl	k	p	t2	lp	TX	sw
ø 4,0	4,1 +0,2/-0,1	3,0 ±0,1	3,0 ±0,15	12,0 ±1,0	7,0	3,0 ±0,4	1,8 ±10%	1,5 -0,5	3,5 ±0,2	15/20	6
ø 4,5	4,6 +0,2/-0,1	3,3 ±0,1	3,4 ±0,15	13,0 ±1,0	8,0	3,2 ±0,4	2,0 ±10%	1,5 -0,5	3,7 ±0,2	20/25	7
ø 5,0	5,3 +0,2/-0,1	3,7 ±0,1	4,0 ±0,15	14,0 ±1,0	9,0	3,5 ±0,4	2,2 ±10%	1,5 -0,5	4,5 ±0,2	20/25	8
ø 6,0	6,5 +0,2/-0,1	4,7 ±0,1	5,0 ±0,15	15,0 ±1,0	11,0	3,8 ±0,4	2,4 ±10%	2,0 -0,5	4,9 ±0,2	25/30	10

Nennmaß/ Nominal dia.	ø 4,0	ø 4,5	ø 5,0	ø 6,0
l min. ±1	23	23	28	36
l max. ±1	80	100	100	110
b ±1	min. /+ k	20	25	30
	max. /+ k	75	90	100

Andere Schraubenlängen im Bereich  $L_{min} \leq L \leq L_{max}$  sind zulässig / Others screws lengths with  $L_{min} \leq L \leq L_{max}$  are allowed

S+P screws

SP-Super-Drill  
Pan washer head timber screw with drilling point, fully threaded

Annex 4.24

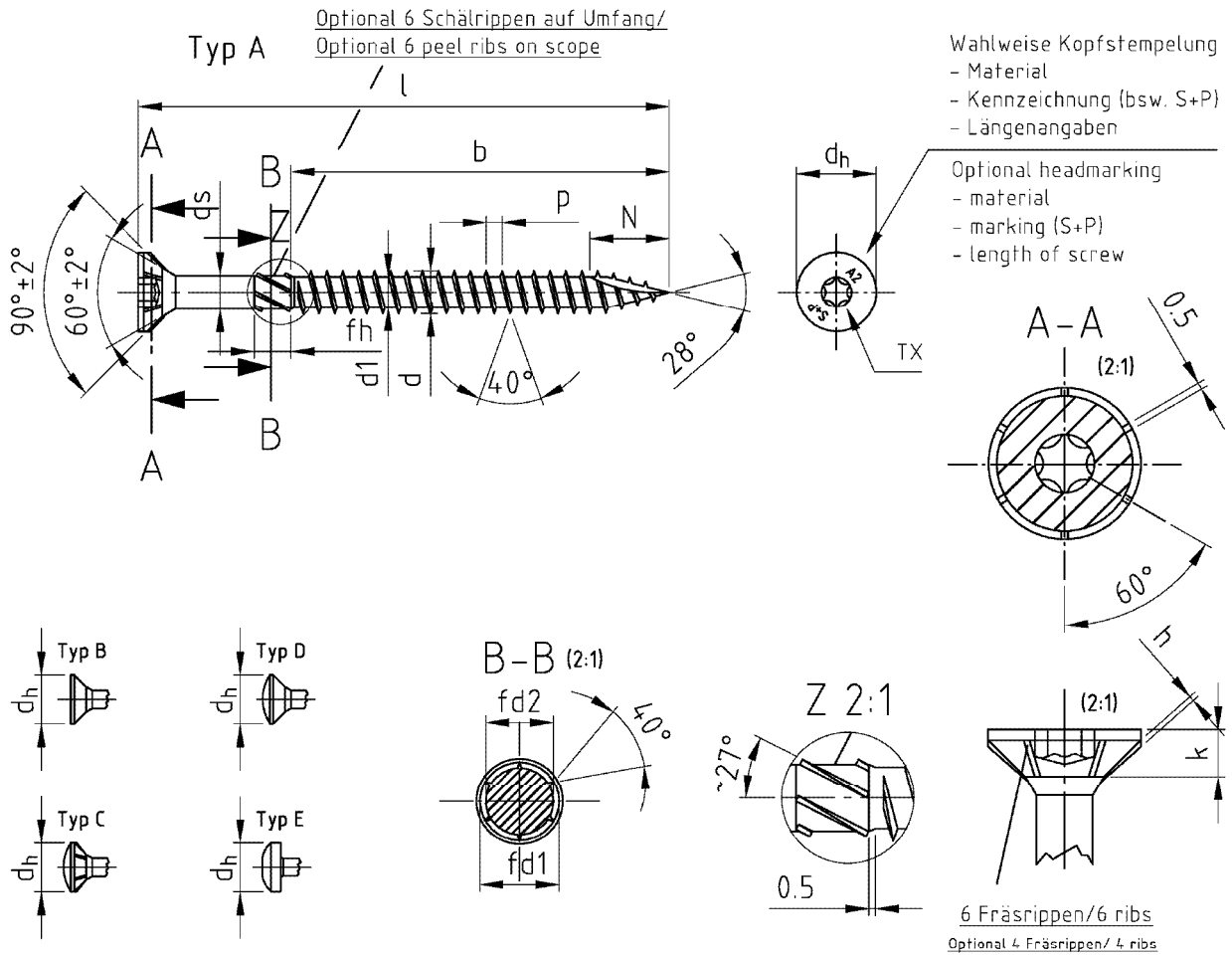

Mit fließendem Übergang vom Gewinde zum Schaft/ with floating crossing between shank and thread

Bezeichnung	SP-Super-Drill/ Seko-Holzbauschrauben mit Schneidkerbe										
Description	SP-Super-Drill/ CSK head wood screws with cutting-point										
Nennmaß/ Nominal dia.	d	d1	dh	ds	k	p	TX	h	fd1	fd2	N
ø 4,0	4,1 +0,2/-0,1	3,0 ±0,1	8,0 -0,5	3,2 ±0,05	2,5 -0,4	1,8 ±10%	15/20	0,35 ±0,1	4,06 -0,25	3,2 -0,15	7,5 ±0,5
ø 4,5	4,6 +0,2/-0,1	3,3 ±0,1	9,0 -0,5	3,5 ±0,05	2,7 -0,4	2,0 ±10%	20/25	0,40 ±0,1	4,36 -0,3	3,5 -0,15	8,5 ±0,5
ø 5,0	5,3 +0,2/-0,1	3,7 ±0,1	10,0 -0,5	4,1 ±0,05	3,0 -0,5	2,2 ±10%	20/25	0,45 ±0,1	5,06 -0,3	4,1 -0,25	9,5 ±0,5
ø 6,0	6,5 +0,2/-0,1	4,7 ±0,1	12,0 -0,5	5,1 ±0,05	3,6 -0,5	2,4 ±10%	25/30	0,50 ±0,1	5,96 -0,3	5,1 -0,25	11,0 ±1,0

l -1/2 IT17	30	35	40	45	50	60	70	80	90	100	120	140-200
ø 4,0 b ±1	21	26	26	28	33	40	50	50	-	-	-	-
ø 4,5 b ±1	-	26	26	31	33	40	50	50	58	58	-	-
ø 5,0 b ±1	-	-	26	30	36	40	50	50	58	58	66	-
ø 6,0 b ±1	-	-	-	-	30	35	47	57	57	66	66	66
fh	4,0 -0,2			6,0 -0,2			12,0 -0,6					

S+P screws

SP-Super-Drill  
CSK head timber screw

Annex 4.25

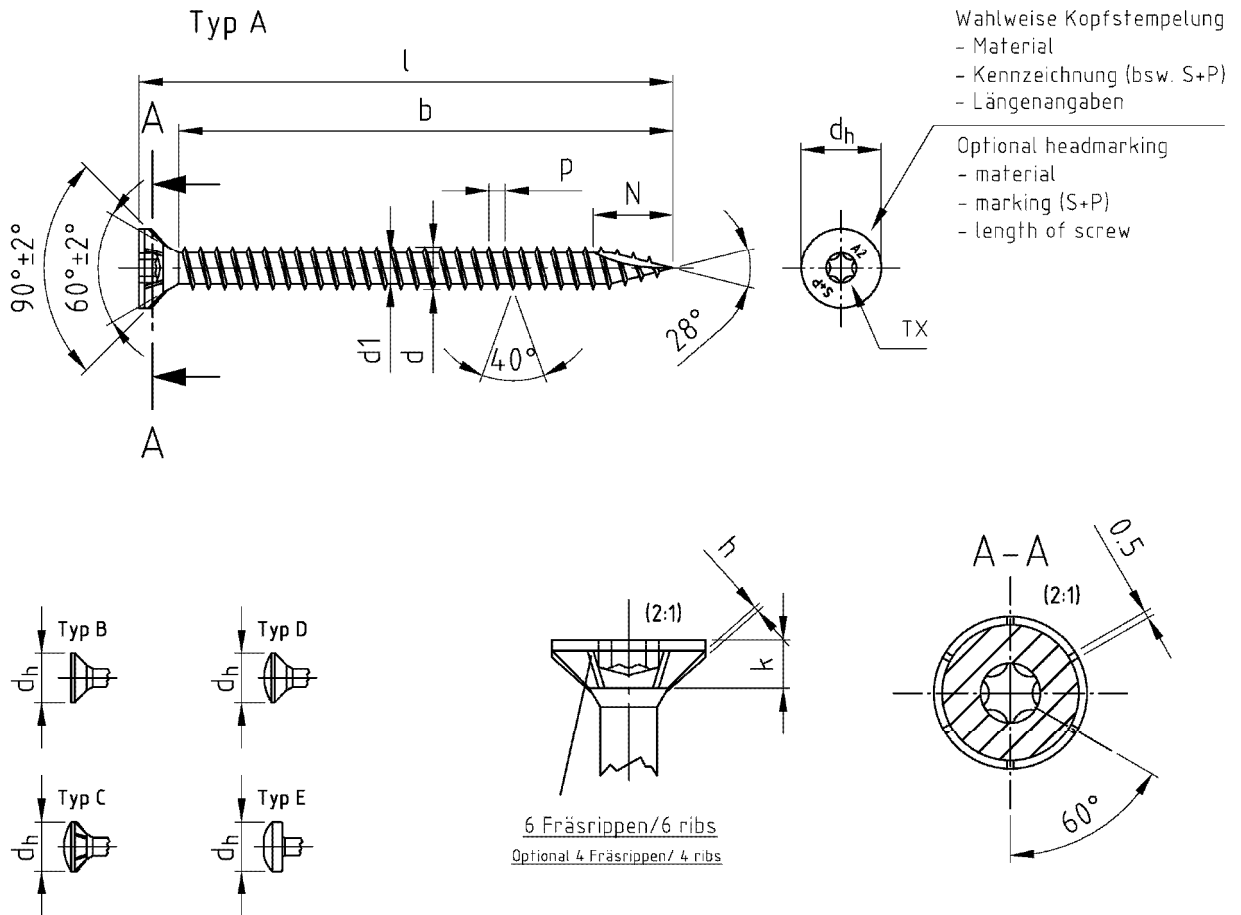

Bezeichnung	SP-Super-Drill/ Seko-Holzbauschrauben mit Schneidkerbe, Vollgewinde								
Description	SP-Super-Drill/ CSK head wood screws with cutting-point, full thread								
Nennmaß/ Nominal dia.	d	d1	dh	k	p	TX	h	N	
ø 4,0	4,1 +0,2/-0,1	3,0 ±0,1	8,0 -0,5	2,5 -0,4	1,8 ±10%	15/20	0,35 ±0,1	7,5 ±0,5	
ø 4,5	4,6 +0,2/-0,1	3,3 ±0,1	9,0 -0,5	2,7 -0,4	2,0 ±10%	20/25	0,40 ±0,1	8,5 ±0,5	
ø 5,0	5,3 +0,2/-0,1	3,7 ±0,1	10,0 -0,5	3,0 -0,5	2,2 ±10%	20/25	0,45 ±0,1	9,5 ±0,5	
ø 6,0	6,5 +0,2/-0,1	4,7 ±0,1	12,0 -0,5	3,6 -0,5	2,4 ±10%	25/30	0,50 ±0,1	11,0 ±1,0	

Nennmaß/ Nominal dia.	ø 4,0	ø 4,5	ø 5,0	ø 6,0
l min. ±1	23	23	28	36
l max. ±1	80	100	100	110
b ±1	min. /+ k	20	25	30
	max. /+ k	75	90	100
Andere Schraubenlängen im Bereich $L_{min} \leq L \leq L_{max}$ sind zulässig / Others screws lengths with $L_{min} \leq L \leq max$ are allowed				

S+P screws

SP-Super-Drill  
CSK head timber screw, fully threaded

Annex 4.26

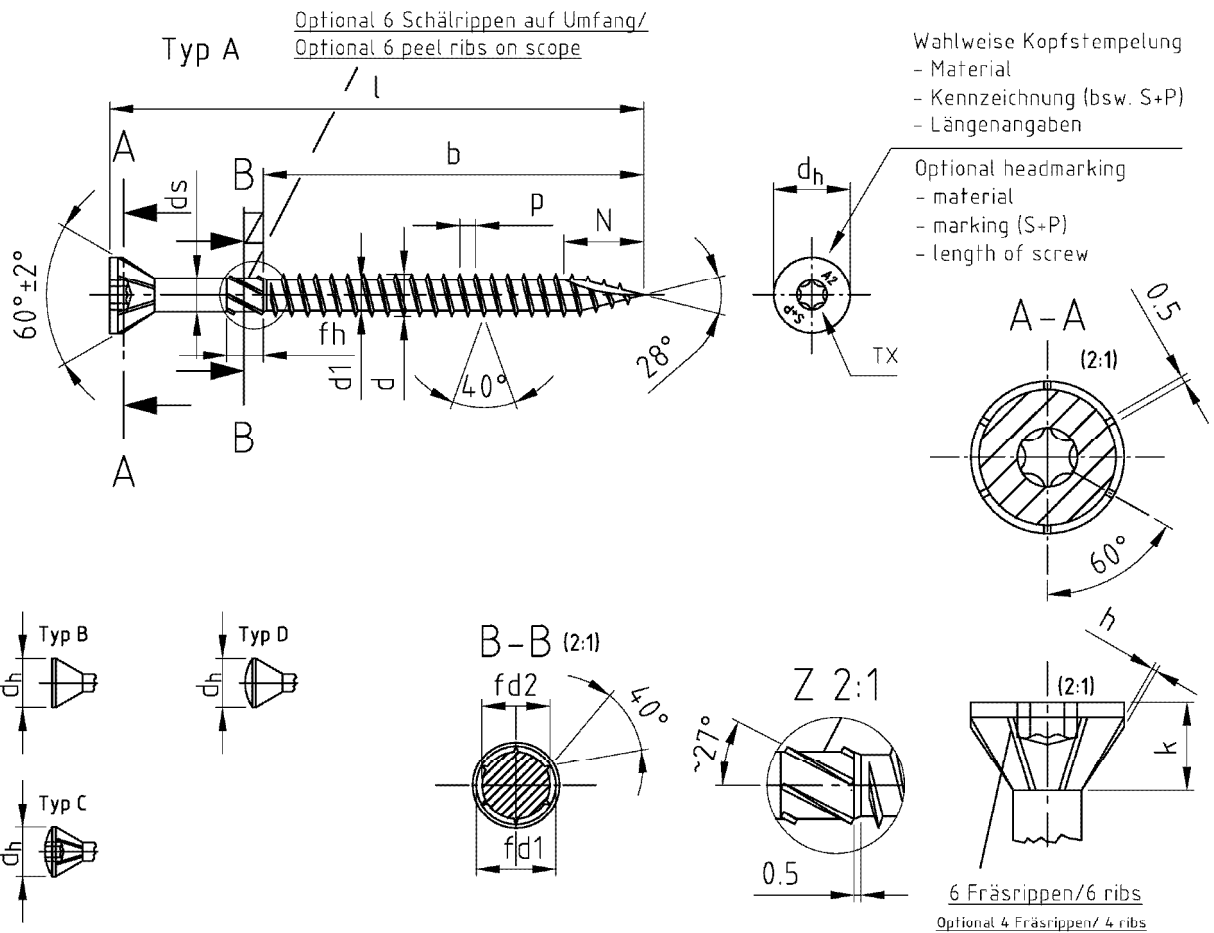

Mit fließendem Übergang vom Gewinde zum Schaft/ with floating crossing between shank and thread

Bezeichnung	SP-Super-Drill 60°/ Seko-Holzbauschrauben mit Schneidkerbe, 60° kopf											
Description	SP-Super-Drill 60°/ CSK head wood screws with cutting-point, 60° head											
Nennmaß/ Nominal dia.	d	d1	dh	ds	k	p	TX	h	fd1	fd2	N	
ø 4,0	4,1 +0,2/-0,1	3,0 ±0,1	7,0 -0,5	3,2 ±0,05	3,3 ±0,5	1,8 ±10%	15/20	0,35 ±0,1	4,06 -0,25	3,2 -0,15	7,5 ±0,5	
ø 4,5	4,6 +0,2/-0,1	3,3 ±0,1	8,0 -0,5	3,5 ±0,05	3,9 ±0,5	2,0 ±10%	20/25	0,40 ±0,1	4,36 -0,3	3,5 -0,15	8,5 ±0,5	
ø 5,0	5,3 +0,2/-0,1	3,7 ±0,1	8,5 -0,5	4,1 ±0,05	4,0 ±0,5	2,2 ±10%	20/25	0,45 ±0,1	5,06 -0,3	4,1 -0,25	9,5 ±0,5	
ø 6,0	6,5 +0,2/-0,1	4,7 ±0,1	11,0 -0,5	5,1 ±0,05	5,1 ±0,5	2,4 ±10%	25/30	0,50 ±0,1	5,96 -0,3	5,1 -0,25	11,0 ±1,0	

l -1/2 IT17	30	35	40	45	50	60	70	80	90	100	120	140-200
ø 4,0 b ±1	21	26	26	28	33	40	50	50	-	-	-	-
ø 4,5 b ±1	-	26	26	31	33	40	50	50	58	58	-	-
ø 5,0 b ±1	-	-	26	30	36	40	50	50	58	58	66	-
ø 6,0 b ±1	-	-	-	-	30	35	47	57	57	66	66	66
fh	4,0 -0,2			6,0 -0,2			12,0 -0,6					

S+P screws

SP-Super-Drill 60°  
CSK head timber screw, 60° head

Annex 4.27

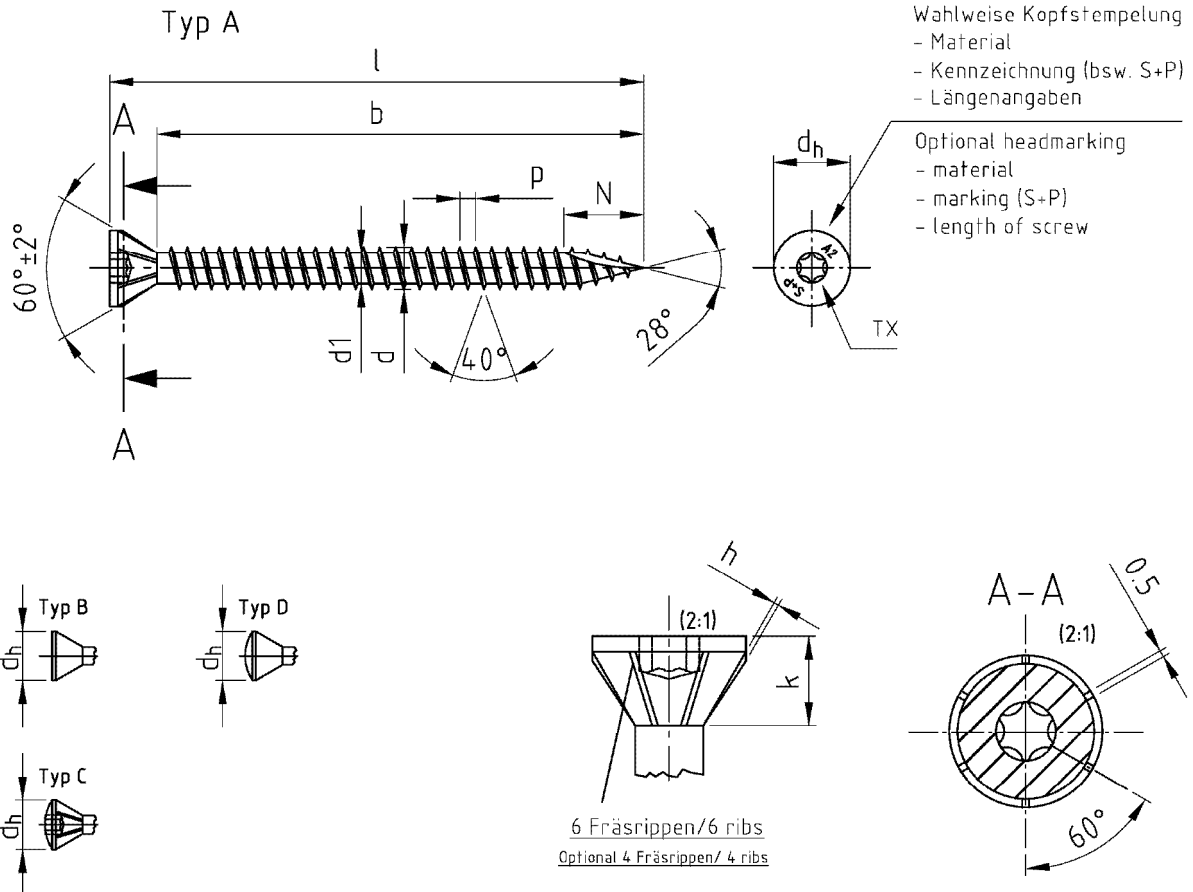

Bezeichnung	SP-Super-Drill 60°/ Seko-Holzbauschrauben mit Schneidkerbe, 60° kopf, Vollgewinde								
Description	SP-Super-Drill 60°/ CSK head wood screws with cutting-point, 60° head, full thread								
Nennmaß/ Nominal dia.	d	d <sub>1</sub>	d <sub>h</sub>	k	p	TX	h	N	
ø 4,0	4,1 +0,2/-0,1	3,0 ±0,1	7,0 -0,5	3,3 ±0,5	1,8 ±10%	15/20	0,35 ±0,1	7,5 ±0,5	
ø 4,5	4,6 +0,2/-0,1	3,3 ±0,1	8,0 -0,5	3,9 ±0,5	2,0 ±10%	20/25	0,40 ±0,1	8,5 ±0,5	
ø 5,0	5,3 +0,2/-0,1	3,7 ±0,1	8,5 -0,5	4,0 ±0,5	2,2 ±10%	20/25	0,45 ±0,1	9,5 ±0,5	
ø 6,0	6,5 +0,2/-0,1	4,7 ±0,1	11,0 -0,5	5,1 ±0,5	2,4 ±10%	25/30	0,50 ±0,1	11,0 ±1,0	

Nennmaß/ Nominal dia.	ø 4,0	ø 4,5	ø 5,0	ø 6,0
l min. ±1	23	23	28	36
l max. ±1	80	100	100	110
b ±1	min. /+ k	20	25	30
	max. /+ k	75	90	100

Andere Schraubenlängen im Bereich  $L_{min} \leq L \leq L_{max}$  sind zulässig / Others screws lengths with  $L_{min} \leq L \leq L_{max}$  are allowed

S+P screws

SP-Super-Drill 60°  
CSK head timber screw, fully threaded, 60° head

Annex 4.28

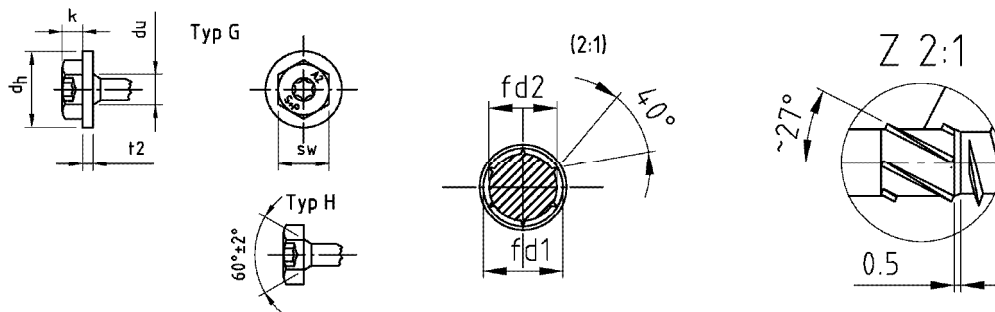
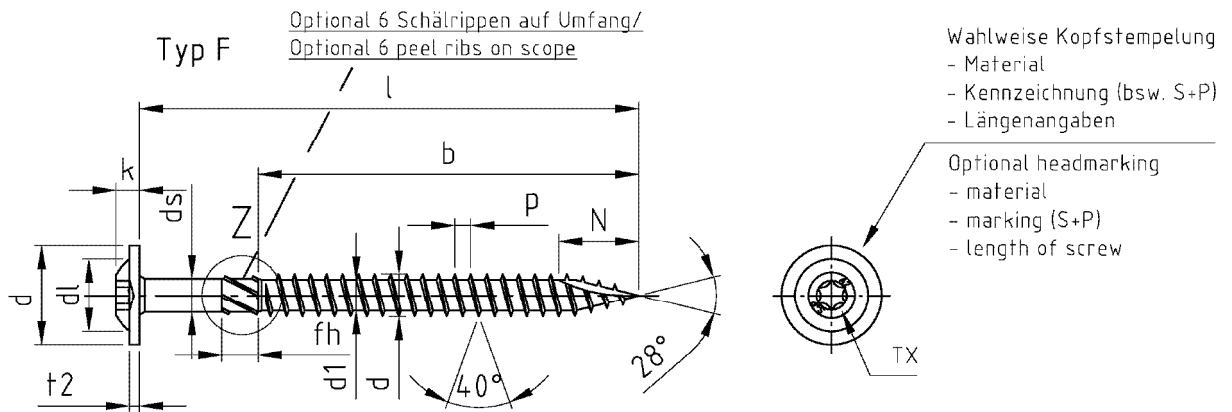

Mit fließendem Übergang vom Gewinde zum Schaft/ with floating crossing between shank and thread

Bezeichnung	SP-Super-Drill/ Tellerkopf-Holzbauschrauben mit Schneidkerbe													
Description	SP-Super-Drill/ Pan washer head timber screws with cutting point													
Nennmaß/ Nominal dia.	d	d1	dh	ds	dl	k	p	t2	TX	sw	fd1	fd2	N	
∅ 4,0	4,1 +0,2/-0,1	3,0 ±0,1	12,0 ±1,0	3,2 ±0,05	7,0	3,0 ±0,4	1,8 ±10%	1,5 -0,5	15/20	6	4,06 -0,25	3,2 -0,15	7,5 ±0,5	
∅ 4,5	4,6 +0,2/-0,1	3,3 ±0,1	13,0 ±1,0	3,5 ±0,05	8,0	3,2 ±0,4	2,0 ±10%	1,5 -0,5	20/25	7	4,36 -0,3	3,5 -0,15	8,5 ±0,5	
∅ 5,0	5,3 +0,2/-0,1	3,7 ±0,1	14,0 ±1,0	4,1 ±0,05	9,0	3,5 ±0,4	2,2 ±10%	1,5 -0,5	20/25	8	5,06 -0,3	4,1 -0,25	9,5 ±0,5	
∅ 6,0	6,5 +0,2/-0,1	4,7 ±0,1	15,0 ±1,0	5,1 ±0,05	11,0	3,8 ±0,4	2,4 ±10%	2,0 -0,5	25/30	10	5,96 -0,3	5,1 -0,25	11,0 ±1,0	

l -1/2 IT17	30	35	40	45	50	60	70	80	90	100	120	140-200
∅ 4,0 b ±1	21	26	26	28	33	40	50	50	-	-	-	-
∅ 4,5 b ±1	-	26	26	31	33	40	50	50	58	58	-	-
∅ 5,0 b ±1	-	-	26	30	36	40	50	50	58	58	66	-
∅ 6,0 b ±1	-	-	-	-	30	35	47	57	57	66	66	66
fh	4,0 -0,2			6,0 -0,2			12,0 -0,6					

S+P screws

SP-Super-Drill  
Pan washer head timber screw

Annex 4.29

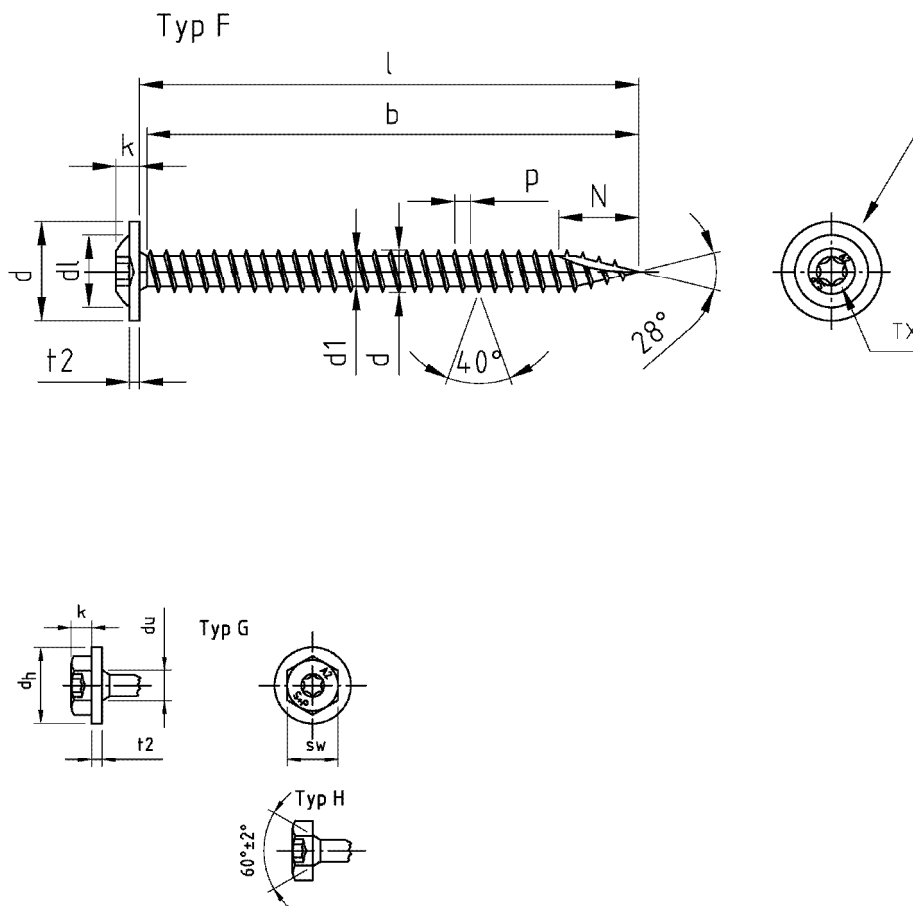

Wahlweise Kopfstempelung  
- Material  
- Kennzeichnung (bsw. S+P)  
- Längenangaben

Optional headmarking  
- material  
- marking (S+P)  
- length of screw

Bezeichnung	SP-Super-Drill/ Tellerkopf-Holzbauschrauben mit Schneidkerbe, Vollgewinde									
Description	SP-Super-Drill/ Pan washer head timber screws with cutting-point, full thread									
Nennmaß/ Nominal dia.	d	d1	dh	d1	k	p	t2	TX	sw	N
ø 4,0	4,1 +0,2/-0,1	3,0 ±0,1	12,0 ±1,0	7,0	3,0 ±0,4	1,8 ±10%	1,5 -0,5	15/20	6	7,5 ±0,5
ø 4,5	4,6 +0,2/-0,1	3,3 ±0,1	13,0 ±1,0	8,0	3,2 ±0,4	2,0 ±10%	1,5 -0,5	20/25	7	8,5 ±0,5
ø 5,0	5,3 +0,2/-0,1	3,7 ±0,1	14,0 ±1,0	9,0	3,5 ±0,4	2,2 ±10%	1,5 -0,5	20/25	8	9,5 ±0,5
ø 6,0	6,5 +0,2/-0,1	4,7 ±0,1	15,0 ±1,0	11,0	3,8 ±0,4	2,4 ±10%	2,0 -0,5	25/30	10	11,0 ±1,0

Nennmaß/ Nominal dia.	ø 4,0	ø 4,5	ø 5,0	ø 6,0
l min. ±1	23	23	28	36
l max. ±1	80	100	100	110
b ±1	min. /+ k	20	25	30
	max. /+ k	75	90	100

Andere Schraubenlängen im Bereich  $L_{min} \leq L \leq L_{max}$  sind zulässig / Others screws lengths with  $L_{min} \leq L \leq L_{max}$  are allowed

S+P screws

SP-Super-Drill  
Pan washer head timber screw, fully threaded

Annex 4.30

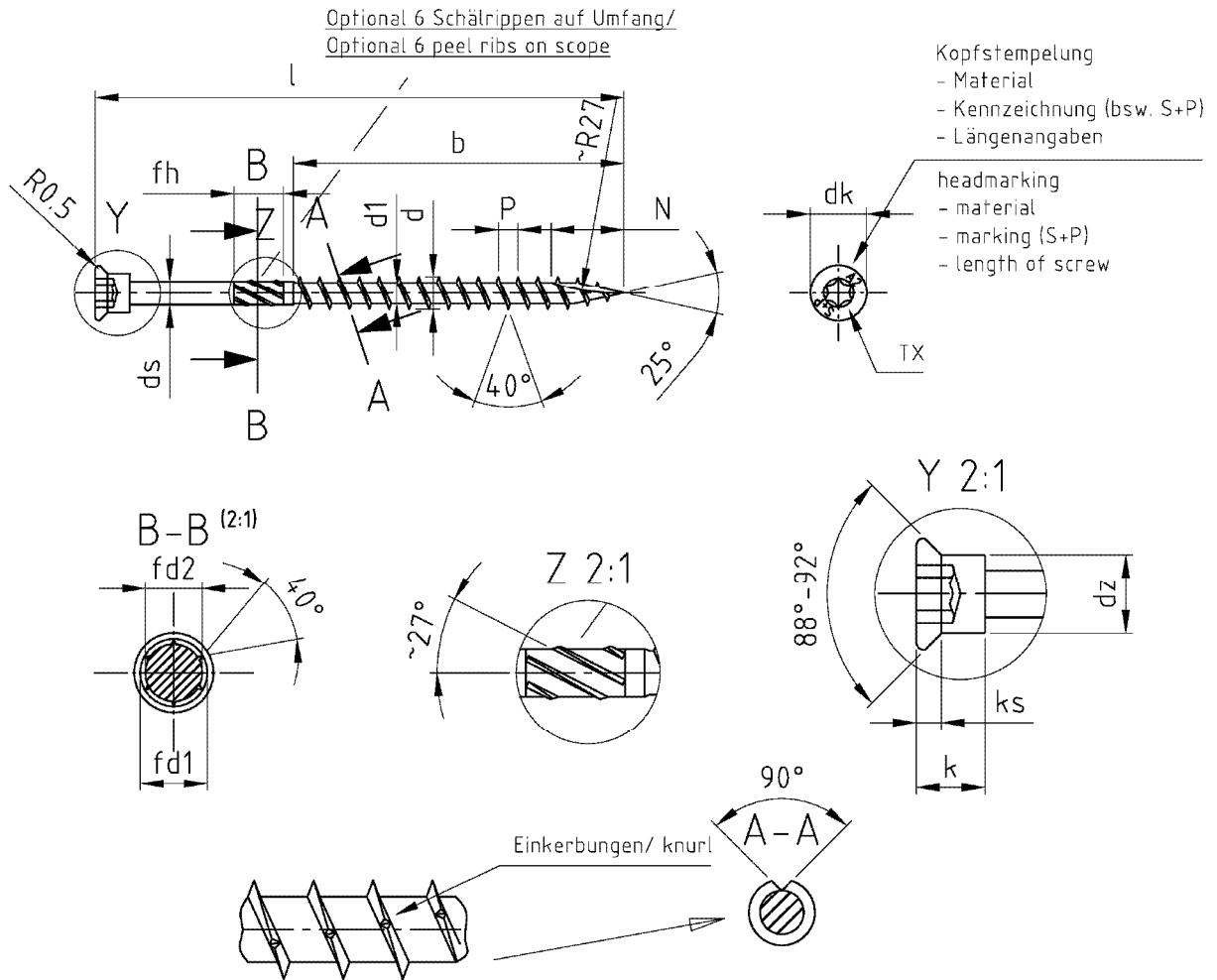

Mit fließendem Übergang vom Gewinde zum Schaft/ with floating crossing between shank and thread

Bezeichnung	SP-Drill/Zyl.-Terrassenbauschrauben, Schneidkerbe											
Description	SP-Drill/ cyl. head terrace screws, cutting-point											
Nennmaß/ Nominal dia.	d	d1	dh	dz	ds	k	ks	p	TX	fd1	fd2	N
ø 4,0	4,0 ±0,15	2,55 ±0,1	5,70 -0,3	3,95 ±0,1	2,8 ±0,05	4,35 -0,25	0,90 -0,3	2,5 ±0,1	15/20	3,4 -0,25	2,7 -0,15	8,7 ±0,5
ø 4,5	4,5 ±0,15	2,9 ±0,1	7,05 -0,3	5,35 ±0,1	3,15 ±0,05	4,8 -0,3	1,10 -0,3	2,8 ±0,1	20/25	3,7 -0,25	2,9 -0,15	9,8 ±0,5
ø 5,0	5,0 ±0,15	3,3 ±0,1	8,75 -0,3	6,15 ±0,15	3,55 ±0,05	5,45 -0,3	1,30 -0,3	3,2 ±0,1	20/25	4,35 -0,3	3,5 -0,15	11,2 ±0,5

l ±1	40	45	50	60	70	80	90	100	
ø 4,0 b ±1	24	24	30	38	42	48	-	-	
ø 4,5 b ±1	-	24	30	38	42	48	54	60	
ø 5,0 b ±1	-	24	30	38	42	48	54	60	
fh	4,0 -0,2			6,0 -0,2			12,0 -0,6		

S+P screws

SP-Drill  
Cylinder head terrace screw

Annex 4.31

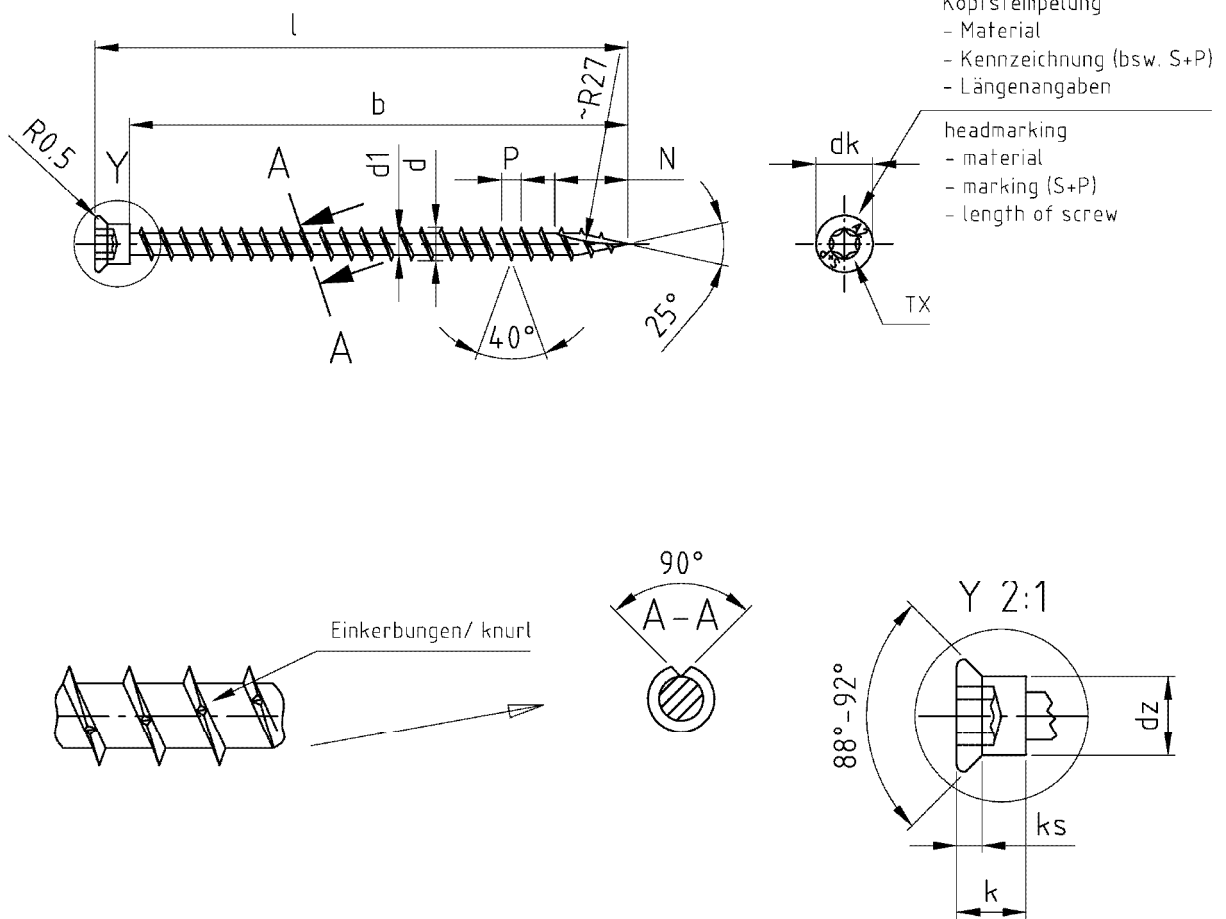

Bezeichnung	SP-Drill/Zyl.-Terrassenbauschrauben, Schneidkerbe, Vollgewinde								
Description	SP-Drill/ cyl. head terrace screws, cutting-point, full thread								
Nennmaß/ Nominal dia.	d	d1	dh	dz	k	ks	p	TX	N
ø 4,0	4,0 ±0,15	2,55 ±0,1	5,70 -0,3	3,95 ±0,1	4,35 -0,25	0,90 -0,3	2,5 ±0,1	15/20	8,7 ±0,5
ø 4,5	4,5 ±0,15	2,9 ±0,1	7,05 -0,3	5,35 ±0,1	4,8 -0,3	1,10 -0,3	2,8 ±0,1	20/25	9,8 ±0,5
ø 5,0	5,0 ±0,15	3,3 ±0,1	8,75 -0,3	6,15 ±0,15	5,45 -0,3	1,30 -0,3	3,2 ±0,1	20/25	11,2 ±0,5

Nennmaß/ Nominal dia.	ø 4,0	ø 4,5	ø 5,0
l min. ±1	23	23	28
l max. ±1	80	100	100
b ±1	min. /+ k	20	25
	max. /+ k	75	90

Andere Schraubenlängen im Bereich  $L_{min} \leq L \leq L_{max}$  sind zulässig / Others screws lengths with  $L_{min} \leq L \leq L_{max}$  are allowed

S+P screws

SP-Drill  
Cylinder head terrace screw, fully threaded

Annex 4.32

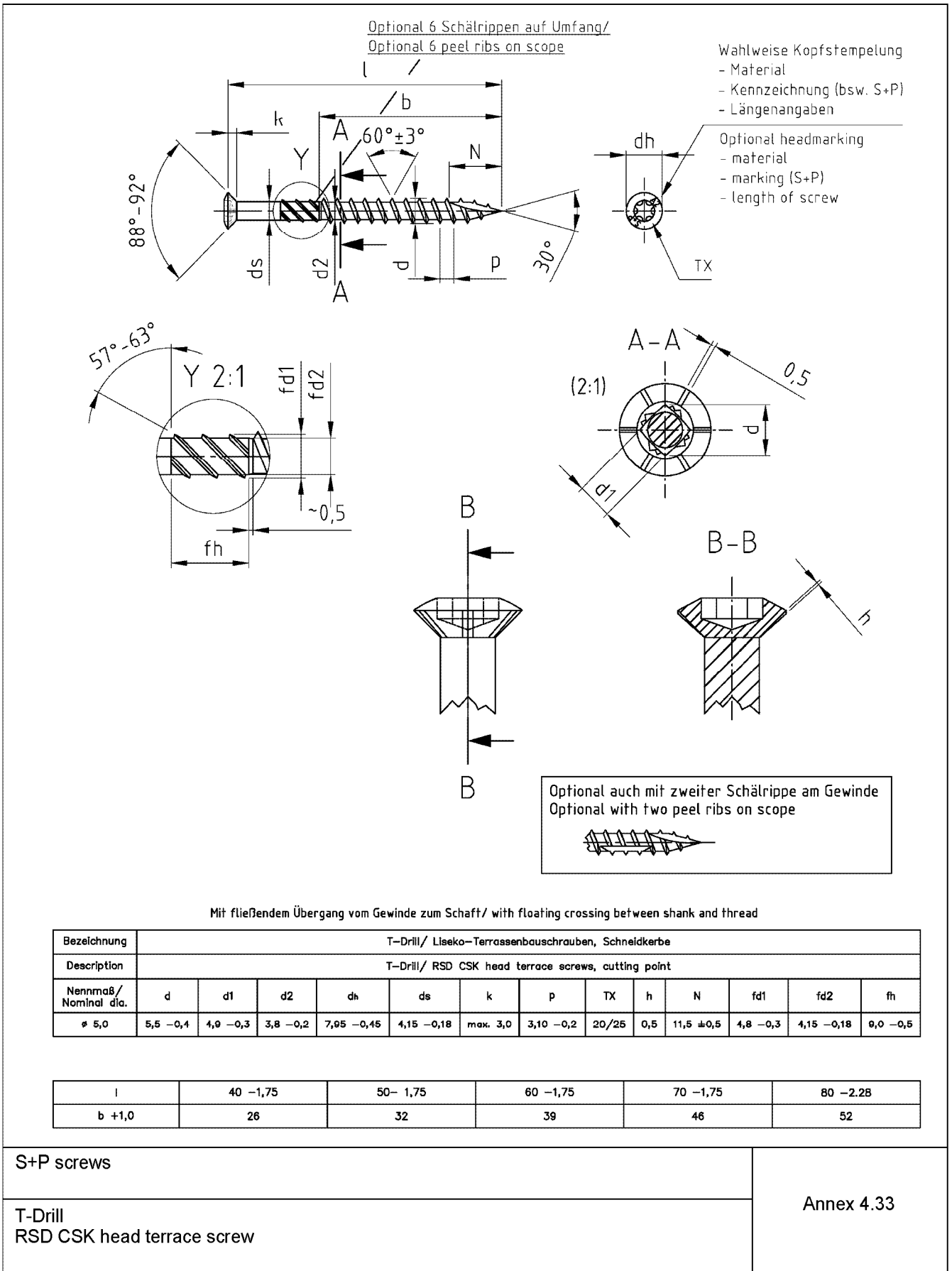

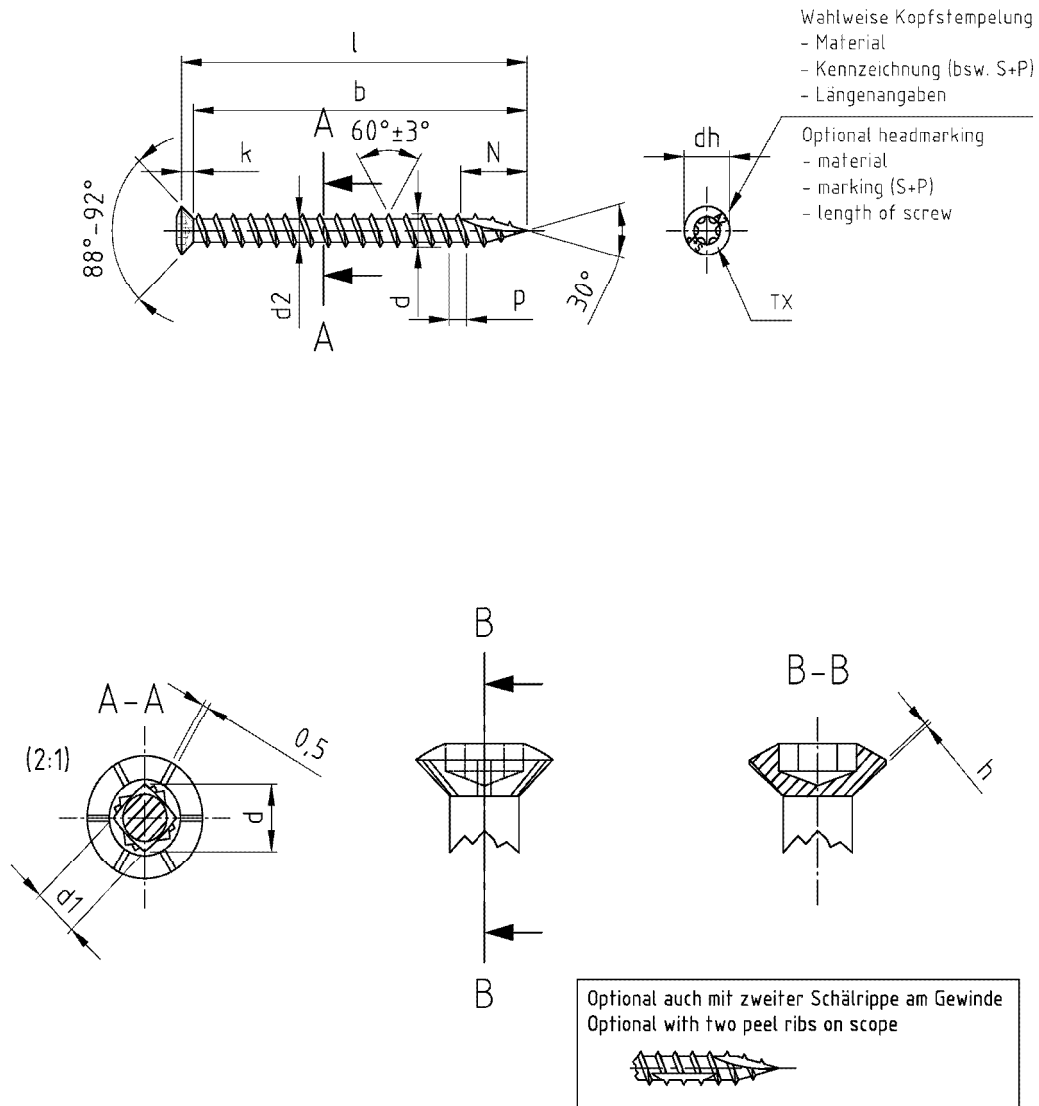

Bezeichnung	T-Drill/ Liseko-Terrassenbauschrauben, Schneidkerbe, Vollgewinde									
Description	T-Drill/ RSD CSK head terrace screws, cutting point, full thread									
Nennmaß/ Nominal dia.	d	d1	d2	dh	k	p	TX	h	N	
∅ 5,0	5,5 -0,4	4,9 -0,3	3,8 -0,2	7,95 -0,45	max. 3,0	3,10 -0,2	20/25	0,5	11,5 ±0,5	

Nennmaß/ Nominal dia.	∅ 5,0	
l min. ±1	28	
l max. ±1	90	
b ±1	min. /+ k	25
	max. /+ k	80
Andere Schraubenlängen im Bereich $L_{min} \leq L \leq L_{max}$ sind zulässig / Others screws lengths with $L_{min} \leq L \leq max$ are allowed		

S+P screws

T-Drill  
RSD CSK head terrace screw, fully threaded

Annex 4.34



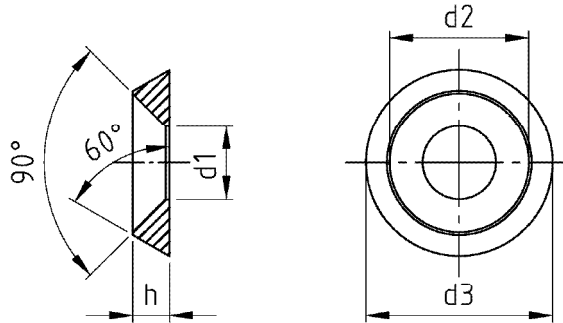

Bezeichnung	SP-Rosette Vollmetal			
Description	SP-Rosette Full Metal			
Nennmaß/ Nominal dia.	d3	d2	d1	h
∅ 4,0	11,0 +0,3	8,0 +0,3	4,5 +0,3	2,5 ±0,2
∅ 5,0	14,0 +0,3	10,0 +0,3	5,5 +0,3	3,0 ±0,2
∅ 6,0	16,0 +0,3	12,0 +0,3	7,0 +0,3	3,5 ±0,2
∅ 8,0	22,0 +0,3	16,0 +0,3	9,0 +0,3	4,5 ±0,2
∅ 10,0	28,0 +0,3	20,0 +0,3	11,0 +0,3	5,5 ±0,2

S+P screws

SP-Rosette  
Washers

Annex 4.36